

As the industry's first surface-mountable connectors to be supplied on a continuous reel, our surface mount connectors are designed to be used as part of Zierick's Surf-Shooter SMT™ (Surface Mount Technology) assembly system to simplify and reduce the cost of surface mount assembly. The complete Surf-Shooter SMT™ system (consisting of connectors supplied on a continuous reel and a special feeder) feeds, separates, and

presents the continuous format, surface-mountable connectors to the pick-up head of the customer's existing placement system.

The continuous format design of the stamped SMT connectors eliminates the need for hand placement or prepackaging that is typically used for surface mount connectors. It eliminates the need for putting the Zierick component in tape and reel, which costs

more than the price of the component itself. Even odd-form components can be fed to the customer's placement system on continuous reels, eliminating hand assembly.

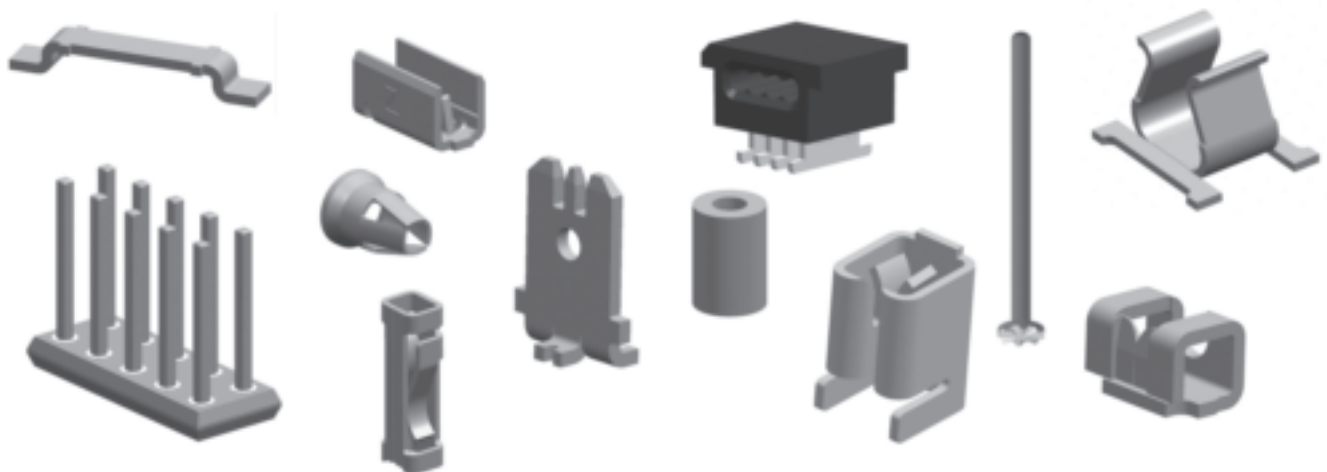

Features and Benefits

- Individual pins can be randomly placed.
- Pins don't float during reflow.
- Pins are reliably perpendicular.
- Zierick offers pins that are designed for .100° on-center applications.
- Certain pins can be selectively plated.
- Many can be produced in different lengths or with different materials for higher conductivity.
- Others provide Z-Axis (axial) compliancy and/or can be used in parallel PCB stacking applications.
- All are designed for automation using the customer's existing pick and place equipment and a special feeder.
- No time-consuming hand placement or costly fixturing is required.

Zierick's SMT pins and posts are specially designed for high-reliability PCB interconnection applications. They are available in many lengths and diameters.

To reduce the applied cost and increase interconnection reliability, Zierick utilizes the capillary action of reflowing solder to prevent the



component from floating and moving on top of the melted solder, and to improve solder joint strength. Pull-force tests reveal that a post with proper capillary action has much higher retention to the printed circuit board than a post without the capillary action feature.

The higher retention force is attributable to two conditions:

- ◆ The first is the very thin layer of solder between the base of the pin and the solder pad. Solder is a weak alloy with a low yield stress. A thicker layer of solder will fail before a thinner layer.

- ◆ As the solder paste reflows, flux and other active ingredients in the solder cause out-gassing. These gases get trapped under a relatively large surface like the base of the pin. The trapped gasses create voids in the solder that are clearly visible when the pin is pulled off or the solder joint is cross-sectioned. Pins that employ capillary action have fewer and smaller voids because the capillary tube provides a way for gasses to escape.



Part Numbers 1216, 6216, 1222, 6222, 6246

U.S. Patent Nos. 5,632,629, 5,695,348, 5,730,608, 5,816,868 and other U.S. and international patents

Zierick recommends .006" stencil thickness for most applications. For other stencil thicknesses, call Zierick's product development department.

Loose Part No.	1216	1222	
Reeled Part No.	6216	6222	6246
Pin Length (L)	0.375" (9.53mm)	0.250" (6.35mm)	0.375" (9.53mm)
Material Thickness / Type	0.012" (0.30mm) Brass		0.012" (0.30mm) CDA 155 Copper
Standard Finish	100% Tin over Copper		
Current Rating	8 Amperes		
Feeder System	Surf-Shooter SMT™ Continuous Strip Feeder		

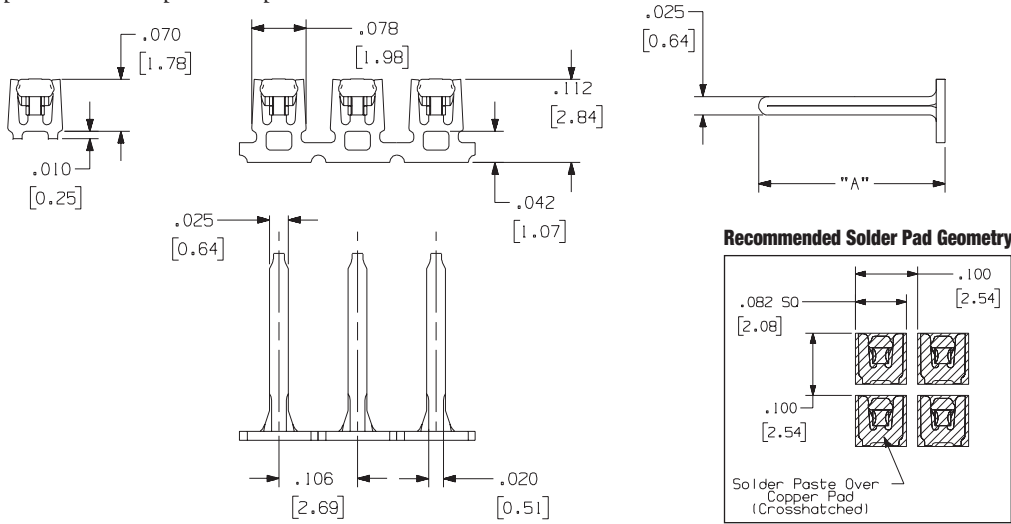

Part Numbers 6239, 6240

U.S. Patent Nos. 5,632,629, 5,695,348, 5,730,608, 5,816,868 and other U.S. and international patents

Zierick recommends .006" stencil thickness for most applications. For other stencil thicknesses, call Zierick's product development department.

Reeled Part No.	6239	6240
Pin Length (L)	0.250" (6.35mm)	0.375" (9.53mm)
Material Thickness / Type	0.012" (0.30mm) Brass	
Standard Finish	100% Tin over Copper	
Current Rating	8 Amperes	
Feeder System	Surf-Shooter SMT™ Continuous Strip Feeder	

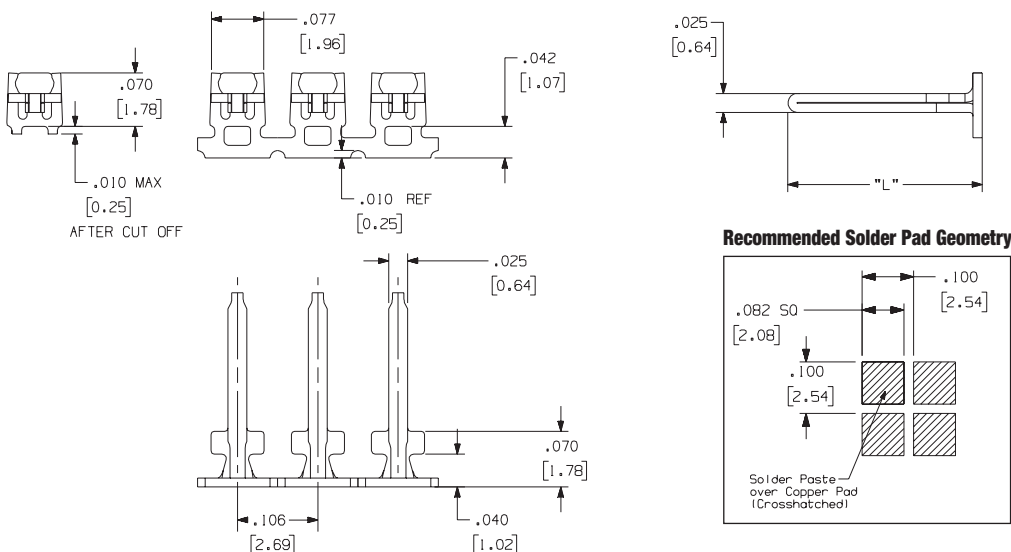

Part Numbers 1264, 6264

U.S. Patent Nos. 6,997,727 B1, 5,730,608, 5,632,629, 5,695,348, 5,816,868 and other U.S. and international patents

Zierick recommends .006" stencil thickness for most applications. For other stencil thicknesses, call Zierick's product development department.

Loose Part No.	1264
Reeled Part No.	6264
Total Length (Height)	0.375" (9.52mm)
Material Thickness / Type	0.012" (0.30mm) C15500 Copper & Silver
Standard Finish	100% Tin over Copper
Current Rating	8 Amperes
Feeder System	Surf-Shooter SMT™ Continuous Strip Feeder

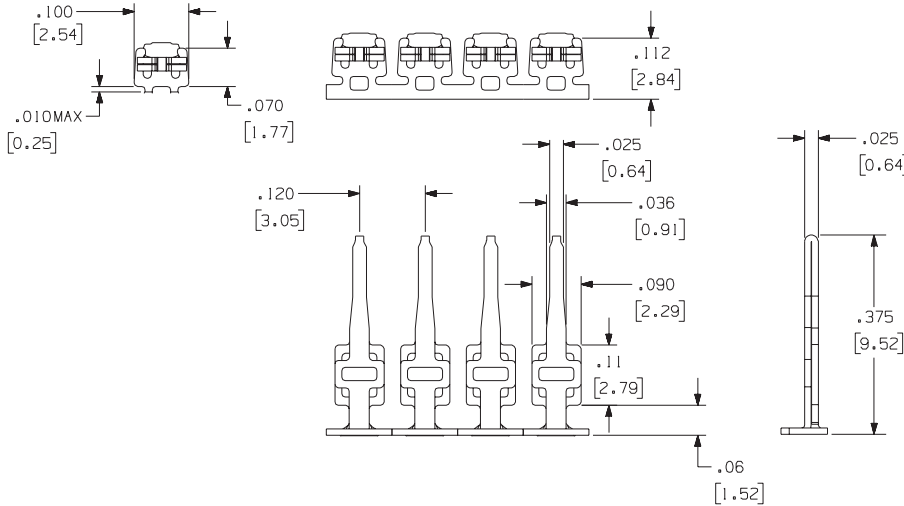

Recommended Solder Pad Geometry

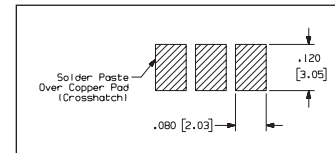

Alternate Solder Pad Geometry

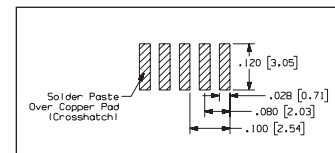

Surface Mount Solid Pins

Part Numbers A1-250, A1-375, A1-421, A1-500, A1-625, A1-750

U.S. Patent Nos. 5,632,629, 5,816,868 and other U.S. and international patents

Zierick recommends .006" stencil thickness for most applications. For other stencil thicknesses, call Zierick's product development department.

Loose Part No.	A1-250	A1-375	A1-421	A1-500	A1-625	A1-750
Dim 'L'	0.250" (6.35mm)	0.375" (9.53mm)	0.421" (10.69mm)	0.500" (12.70mm)	0.625" (15.88mm)	0.750" (19.05mm)
Pin Width	0.025" (0.64mm) Square					
Standard Finish	100% Tin over Copper					
Current Rating	8/Pin					
Feeder System	Pin-Shooter SMT Loose Piece Feeder (Pin Shooter)					

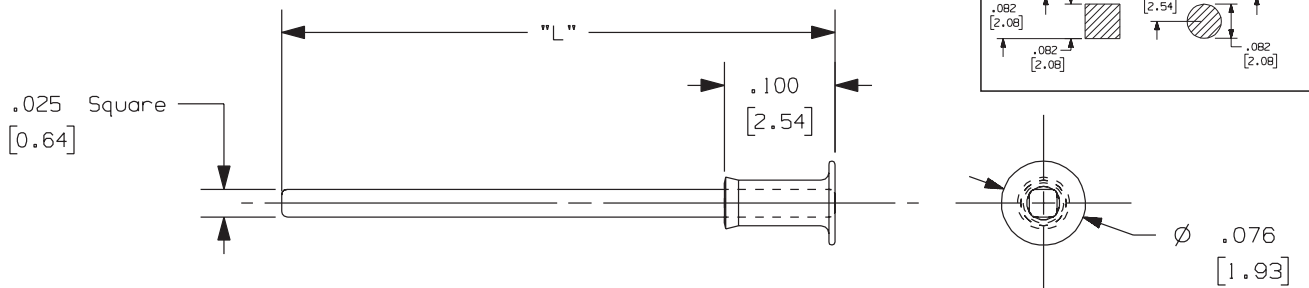

Recommended Solder Pad Geometry

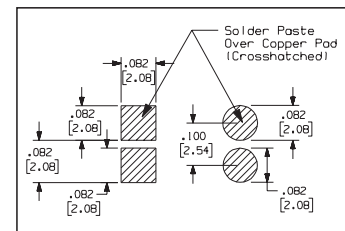

Part Numbers

**A2-375-0, A2-495-0,
A2-532-0, A2-670-0,
A2-680-0, A3-595-0,
A3-625-0, A3-680-0,
A3-800-0, A4-375-0,
A4-625-0, A4-680-0**

U.S. Patent Nos. 5,632,629,
5,695,348, 5,730,608, 5,816,868
and other U.S. and international
patents

Zierick recommends .006" stencil
thickness for most applications.
For other stencil thicknesses, call
Zierick's product development
department.

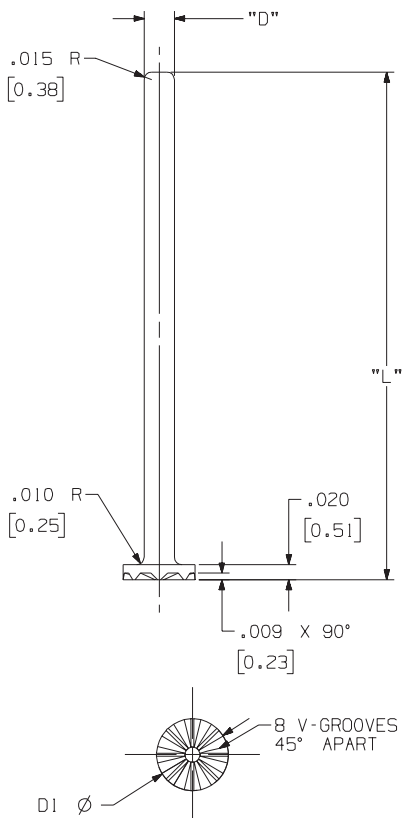

Part No.	DESCRIPTION	L*	D	D1	PAD	CURRENT RATING
A2-375-0	0.040" (1.02mm) Dia x 0.375" (9.53mm) long Solid Copper SMT Post; 100% Tin over CDA 11000	0.375" (9.53mm)	0.040" (1.02mm)	0.095" ± 0.005 " (2.41mm ± 0.127 mm)	A	15 Amperes
A2-495-0	0.040" (1.02mm) Dia x 0.495" (12.57mm) long Solid Copper SMT Post; 100% Tin over CDA 11000	0.495" (12.57mm)	0.040" (1.02mm)	0.095" ± 0.005 " (2.41mm ± 0.127 mm)	A	15 Amperes
A2-532-0	0.040" (1.02mm) Dia x 0.532" (13.51mm) long Solid Copper SMT Post; 100% Tin over CDA 11000	0.532" (13.51mm)	0.040" (1.02mm)	0.095" ± 0.005 " (2.41mm ± 0.127 mm)	A	15 Amperes
A2-670-0	0.040" (1.02mm) Dia x 0.670" (17.02mm) long Solid Copper SMT Post; 100% Tin over CDA 11000	0.670" (17.02mm)	0.040" (1.02mm)	0.095" ± 0.005 " (2.41mm ± 0.127 mm)	A	15 Amperes
A2-680-0	0.040" (1.02mm) Dia x 0.680" (17.27mm) long Solid Copper SMT Post; 100% Tin over CDA 11000	0.680" (17.27mm)	0.040" (1.02mm)	0.095" ± 0.005 " (2.41mm ± 0.127 mm)	A	15 Amperes
A3-595-0	0.060" (1.52mm) Dia x 0.595" (15.11mm) long Solid Copper SMT Post; 100% Tin over CDA 11000	0.595" (15.11mm)	0.060" (1.52mm)	0.120" ± 0.005 " (3.05mm ± 0.127 mm)	B	20 Amperes
A3-625-0	0.060" (1.52mm) Dia x 0.625" (15.88mm) long Solid Copper SMT Post; 100% Tin over CDA 11000	0.625" (15.88mm)	0.060" (1.52mm)	0.120" ± 0.005 " (3.05mm ± 0.127 mm)	B	20 Amperes
A3-680-0	0.060" (1.52mm) Dia x 0.680" (17.27mm) long Solid Copper SMT Post; 100% Tin over CDA 11000	0.680" (17.27mm)	0.060" (1.52mm)	0.120" ± 0.005 " (3.05mm ± 0.127 mm)	B	20 Amperes
A3-800-0	0.060" (1.52mm) Dia x 0.800" (20.32mm) long Solid Copper SMT Post; 100% Tin over CDA 11000	0.800" (20.32mm)	0.060" (1.52mm)	0.120" ± 0.005 " (3.05mm ± 0.127 mm)	B	20 Amperes
A4-375-0	0.080" (2.03mm) Dia x 0.375" (9.53mm) long Solid Copper SMT Post; 100% Tin over CDA 11000	0.375" (9.53mm)	0.080" (2.03mm)	0.140" ± 0.010 " (3.56mm ± 0.254 mm)	C	25 Amperes
A4-625-0	0.080" (2.03mm) Dia x 0.625" (15.88mm) long Solid Copper SMT Post; 100% Tin over CDA 11000	0.625" (15.88mm)	0.080" (2.03mm)	0.140" ± 0.010 " (3.56mm ± 0.254 mm)	C	25 Amperes
A4-680-0	0.080" (2.03mm) Dia x 0.680" (17.27mm) long Solid Copper SMT Post; 100% Tin over CDA 11000	0.680" (17.27mm)	0.080" (2.03mm)	0.140" ± 0.010 " (3.56mm ± 0.254 mm)	C	25 Amperes

Feeder System: Pin-Shooter SMT Loose Piece Feeder (Pin Shooter)

Pad A - Recommended Solder Pad Geometry

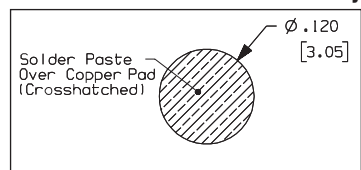

Pad B - Recommended Solder Pad Geometry

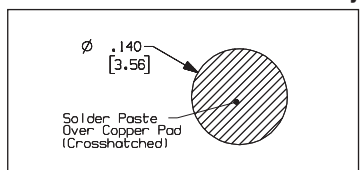

Pad C - Recommended Solder Pad Geometry

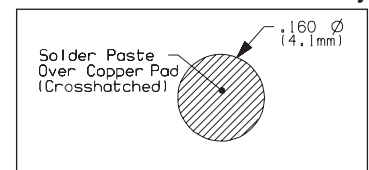

* Additional Pin Lengths available upon request. Please consult factory.

Features and Benefits

- Zierick Tabs / Quick Disconnects have high retention forces.
- The shoulder provides a stand-off for the mating part from the PCB.
- They retain typical through-hole Tab / Quick Disconnect features.
- They don't float during reflow.
- All are designed for automation using the customer's existing pick and place equipment and a special feeder, and require no time consuming hand placement or costly fixturing.
- Most Tabs can be automated using standard tape feeders.



Zierick's family of Surface Mount Tabs / Quick Disconnects is now easier than ever to use. They are supplied on reels for easy application by our Surf-Shooter SMT™ Continuous Strip Feeders, in loose piece for lower volumes, or in Surface Mount Tape Pockets. Any Tab which is available in Tape can be purchased in Small Reels for prototyping.

Many of our Surface Mount Tabs / Quick Disconnects have been designed for easy "gripper" pick-up from Tape Pockets, and can be placed by the customer's existing placement systems.

For other requirements, please consult Zierick.



Part Number 1278

Zierick recommends .006" stencil thickness for most applications. For other stencil thicknesses, call Zierick's product development department.

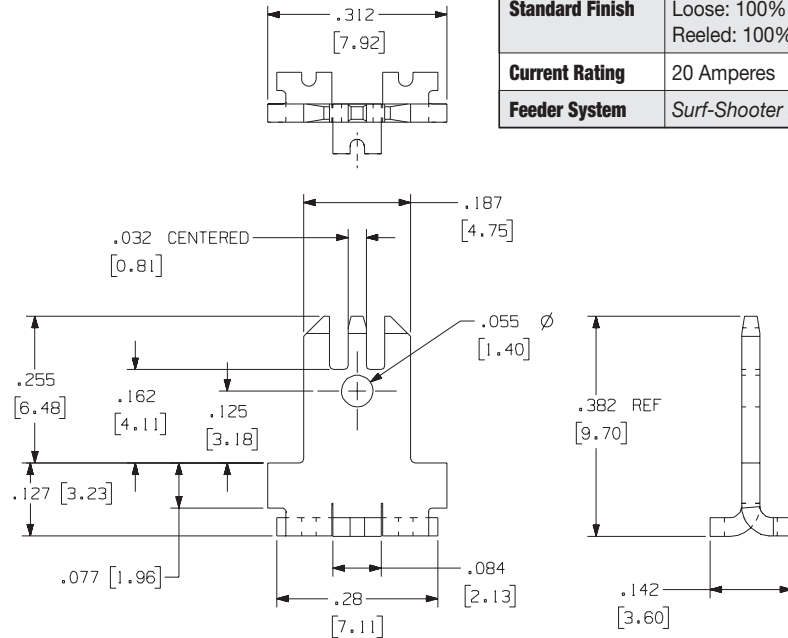

Loose Part No.	1278
Hole Dimension	0.055" (1.40mm)
Material Thickness / Type	0.032" (0.81mm) Brass
Standard Finish	Loose: 100% Tin over Copper Reeled: 100% Tin over Copper
Current Rating	20 Amperes
Feeder System	Surf-Shooter SMT™ Continuous Strip Feeder

Recommended Solder Pad Geometry

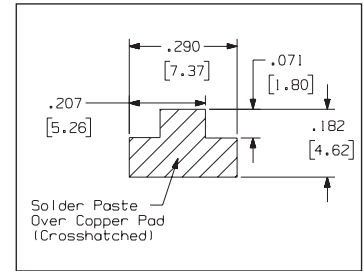

Mating receptacle first withdrawal force may not exceed the UL310 spec. of 18 lbs. max.

A 2oz. PCB Copper trace recommended.

Part Number 6291

Zierick recommends .006" stencil thickness for most applications. For other stencil thicknesses, call Zierick's product development department.

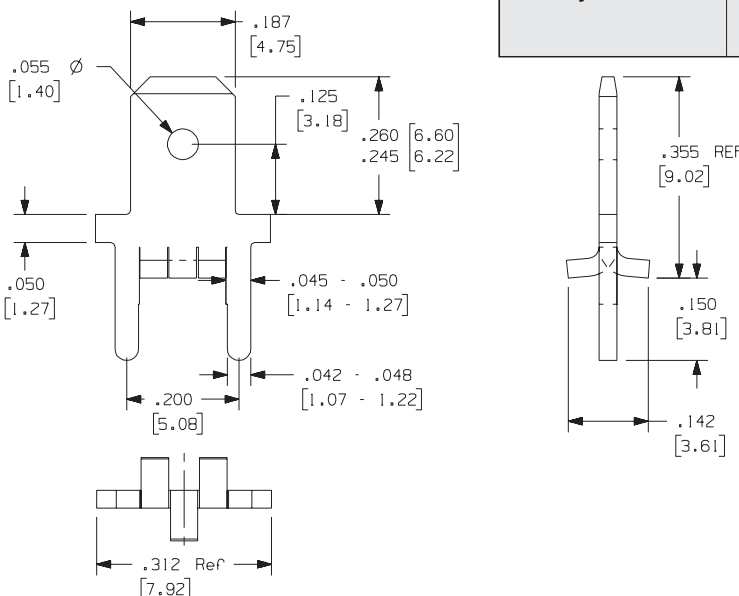

Loose Part No.	N/A
Reeled	6291
Hole Dimension	0.055" (1.408mm) hole
Material Thickness / Type	0.032" (0.81mm) Brass
Standard Finish	100% Tin over Copper
Current Rating	25 Amperes
Feeder System	Surf-Shooter SMT™ Continuous Strip Feeder Model 9700 Model 9700 XY

Recommended Solder Pad Geometry

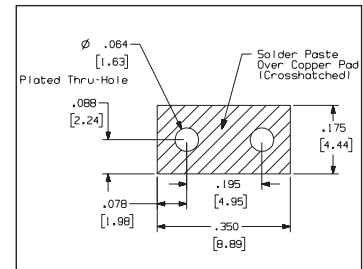

Part Number 6284

Zierick recommends .006" stencil thickness for most applications. For other stencil thicknesses, call Zierick's product development department.

Loose Part No.	N/A
Reeled	6284
Hole Dimension	0.070" (1.78mm) hole
Material Thickness / Type	0.032" (0.81mm) Brass
Standard Finish	100% Tin over Copper
Current Rating	25 Amperes
Feeder System	Surf-Shooter SMT™ Continuous Strip Feeder Model 9700 Model 9700 XY

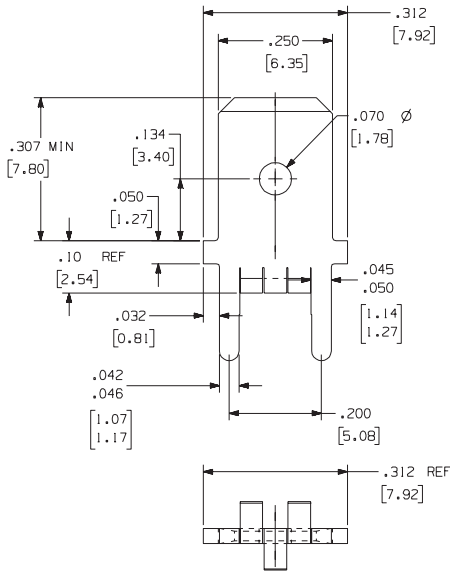

Recommended Solder Pad Geometry

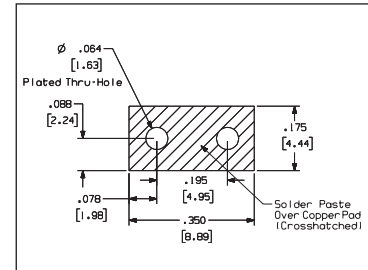

Part Numbers 1285, 6285, 1285TG, 1285TG-SR

Zierick recommends .006" stencil thickness for most applications. For other stencil thicknesses, call Zierick's product development department.

Loose Part No.	1285
Strip	6285
Taped	1285TG 1285TG-SR
Hole Dimension	0.070" (1.78mm) hole
Material Thickness / Type	0.032" (0.81mm) Brass
Standard Finish	100% Tin over Copper
Current Rating	25 Amperes
Feeder System	Surf-Shooter SMT™ Continuous Strip Feeder for PN 6285 Standard 24mm Tape Feeder for PN 1285TG

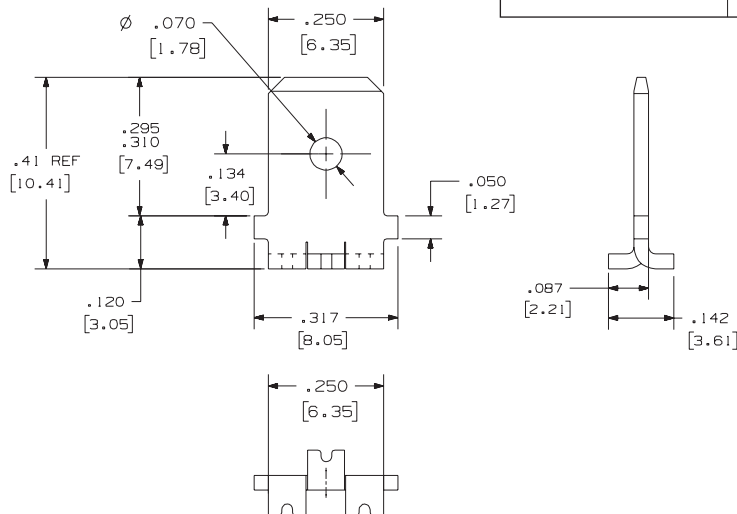

Recommended Solder Pad Geometry

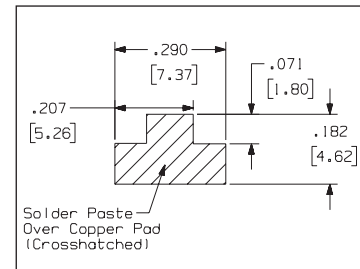

Mating receptacle first withdrawal force may not exceed the UL310 spec. of 18 lbs. max.

A 2oz. PCB Copper trace recommended.

Features and Benefits

- Co-planarity problems are eliminated.
- Minimal real estate is required on the board.
- They have 50% higher pin retention force.
- Optional configurations are available.
- Single Row, Double Row, Horizontal, and Matrix versions are available.
- They allow more forgiving board placement tolerances.
- A visual indicator assures quality processing.
- They are resistant to thermal shock and thermal cycling due to similarity of materials.

Zierick's unique header assembly features capillary action to improve solder joint strength and to reduce the component footprint on the PCB. As a result, pin retention forces are 50% higher than that of J-Lead type headers. As the capillary action draws the solder, it pulls the header assembly tightly to the PCB. At the same time, co-planarity problems are eliminated because the force generated by the capillary action also pulls the header into proper position over

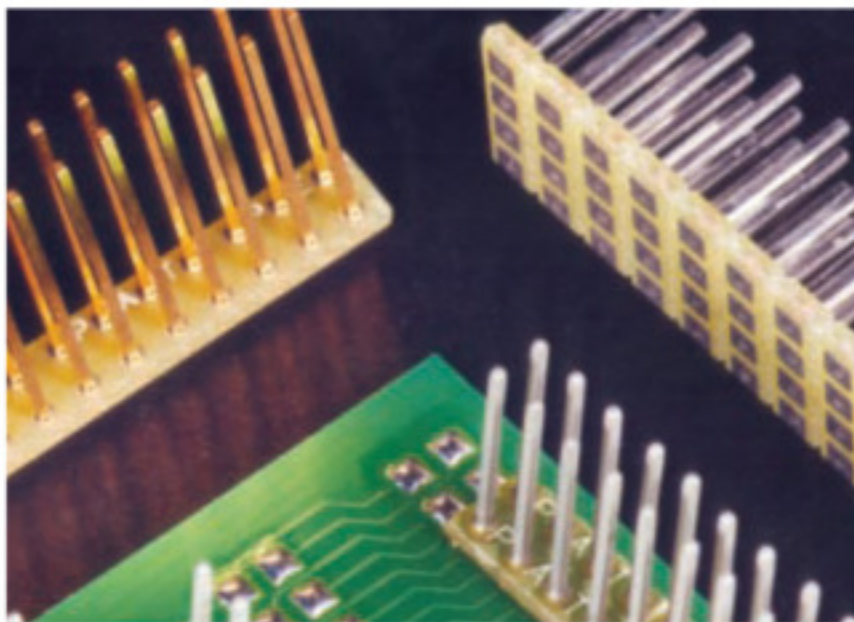

the solder pad, even if the part has been placed off-center.

A circular solder pad on top of the board and a square solder pad on the bottom are connected to the conductive wall of the plated through-hole. The size of the hole is such that it holds the square pin in place, yet leaves four cavities defined by the flat sides of the pin and the curved wall of the hole. These cavities promote capillary action by drawing most of the melted solder up through the cavities where it forms a ring at

the top side of the header assembly board. This solder ring is a visual indication that the reflow process is perfect and complete.

Further, because the header base is made of the same material as the PCB, there are no thermally induced stresses on the solder joint. Long-term reliability is assured. In addition, deep score lines run across both sides of the header base. The assembly is very flexible and can accommodate board warpage without weakening connections.

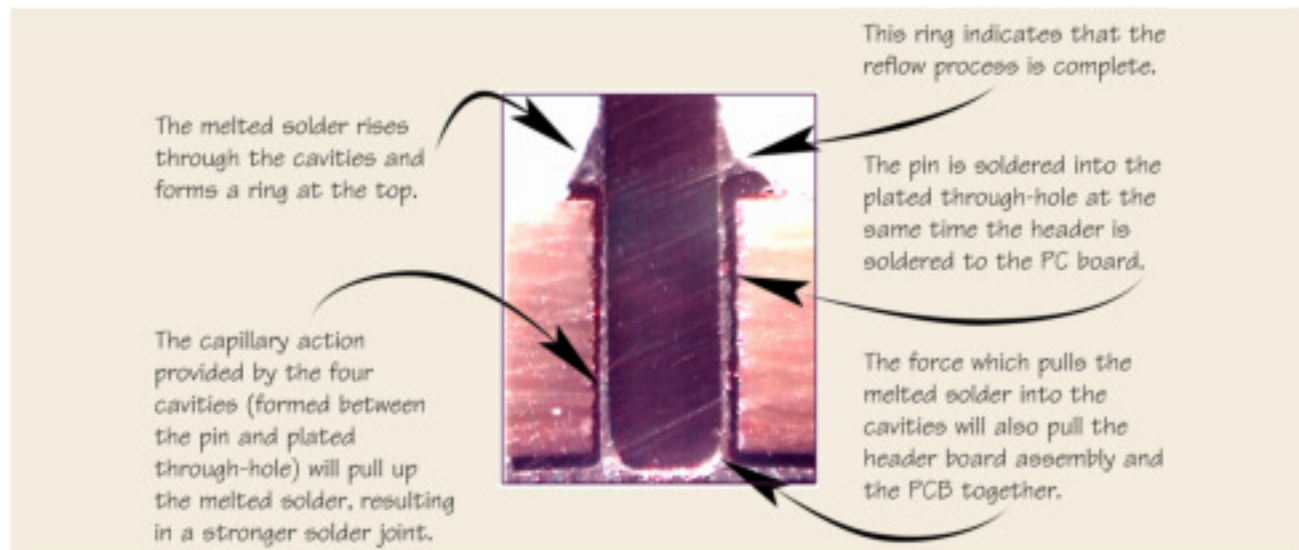

12 0.025" (.635mm) SMT Pin Headers

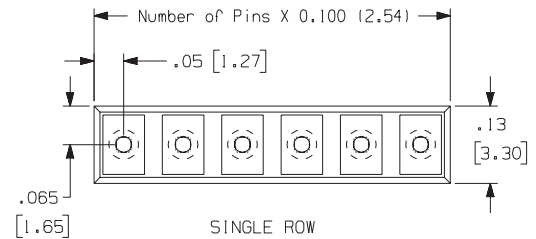
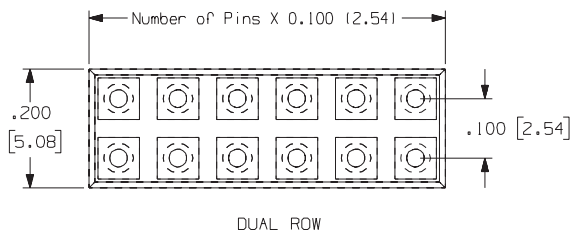
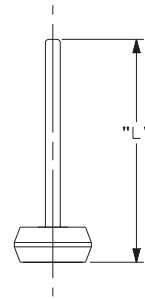
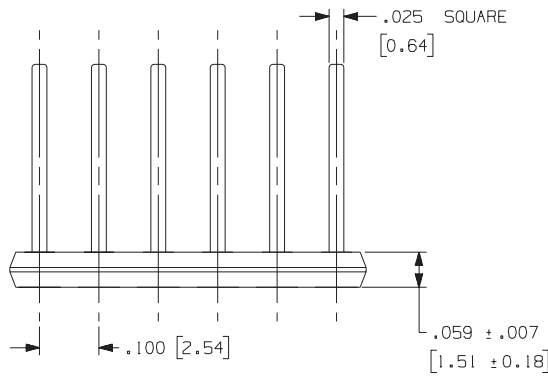
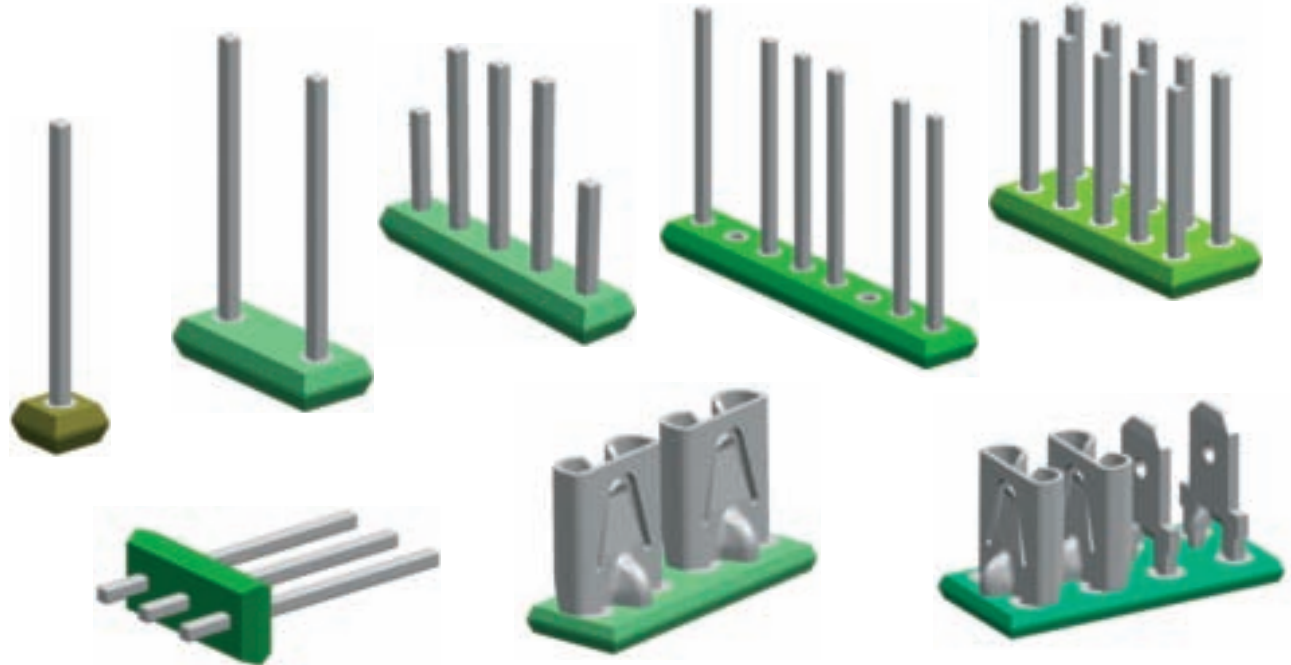

Recommended Solder Pad Geometry

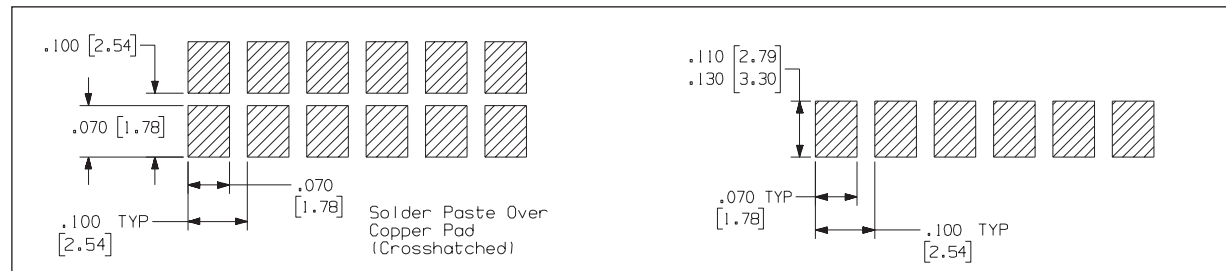

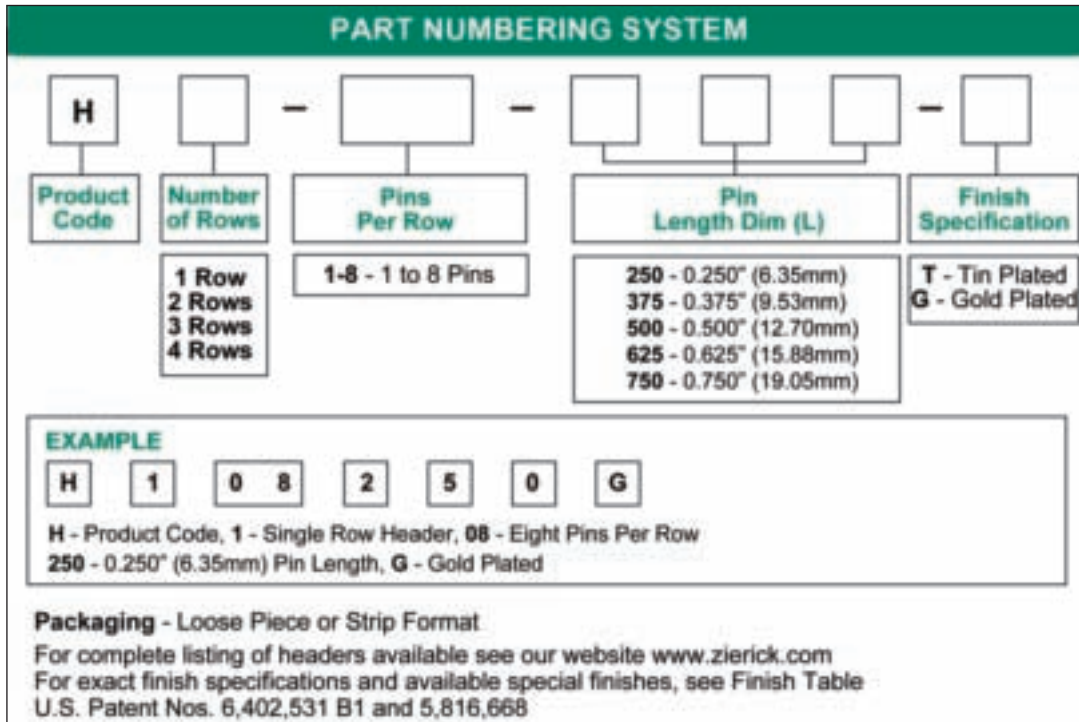

See available Part Numbers at www.zierick.com

SMT One Pin Headers

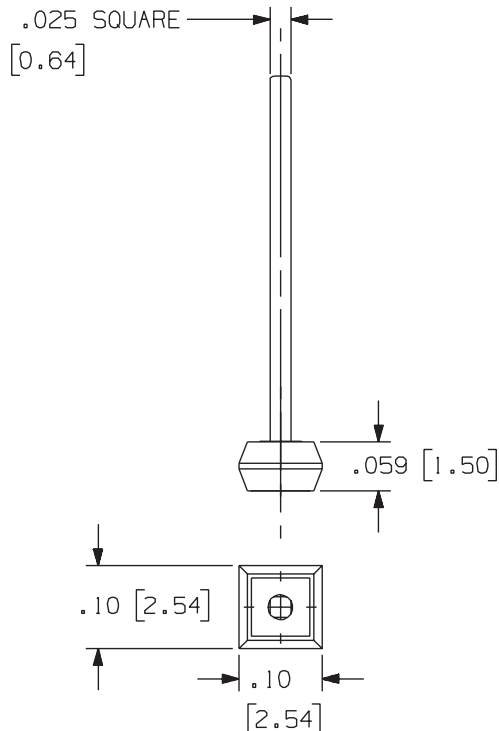

Recommended Solder Pad Geometry

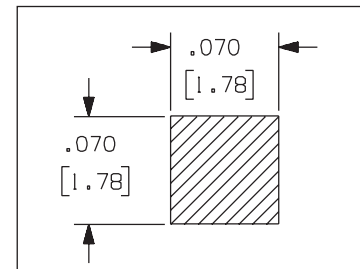

See available Part Numbers at www.zierick.com

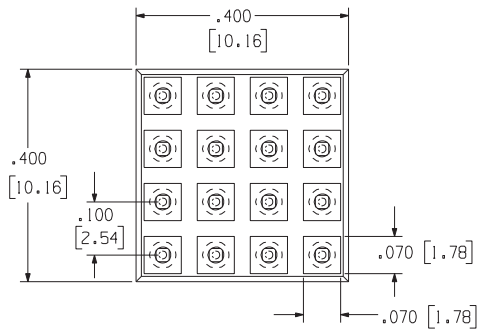
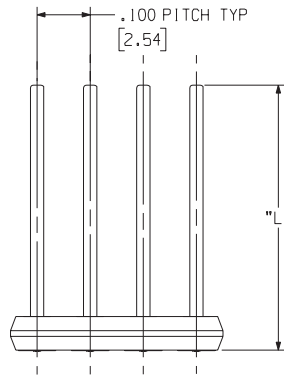
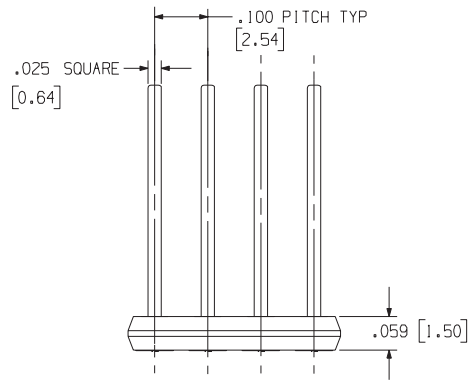

Recommended Solder Pad Geometry

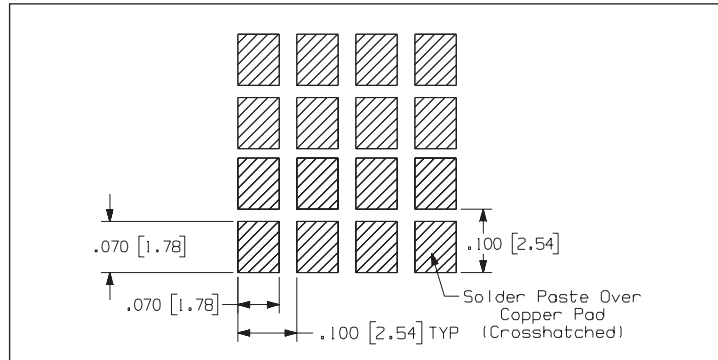

See available Part Numbers at www.zierick.com

SMT Horizontal Pin Headers

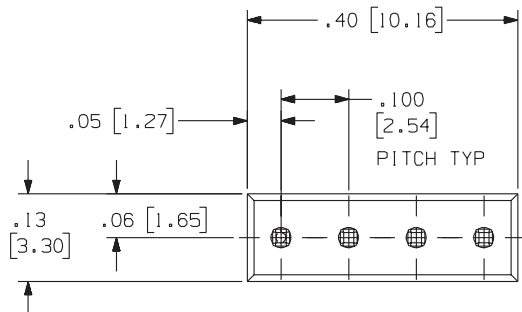
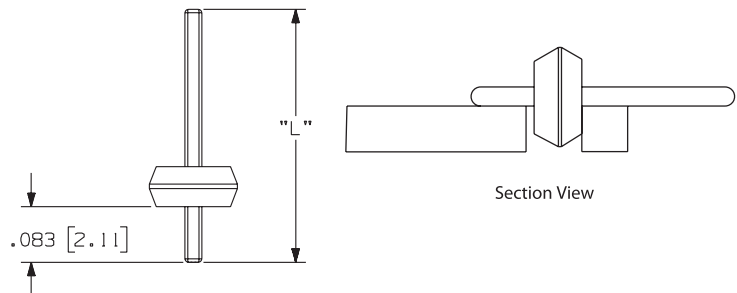
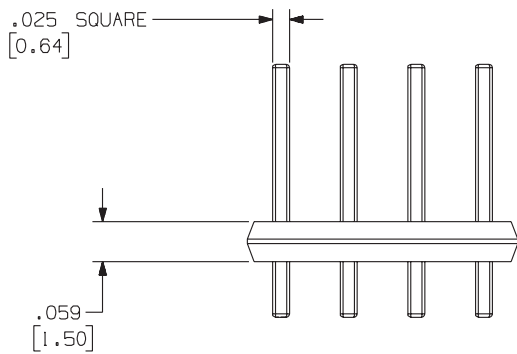

Recommended Solder Pad Geometry

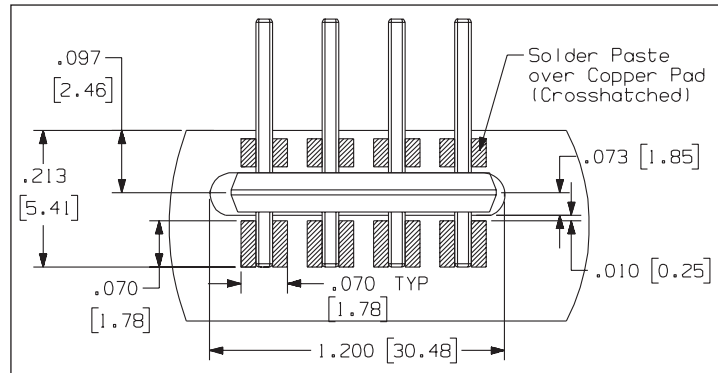

See available Part Numbers at www.zierick.com

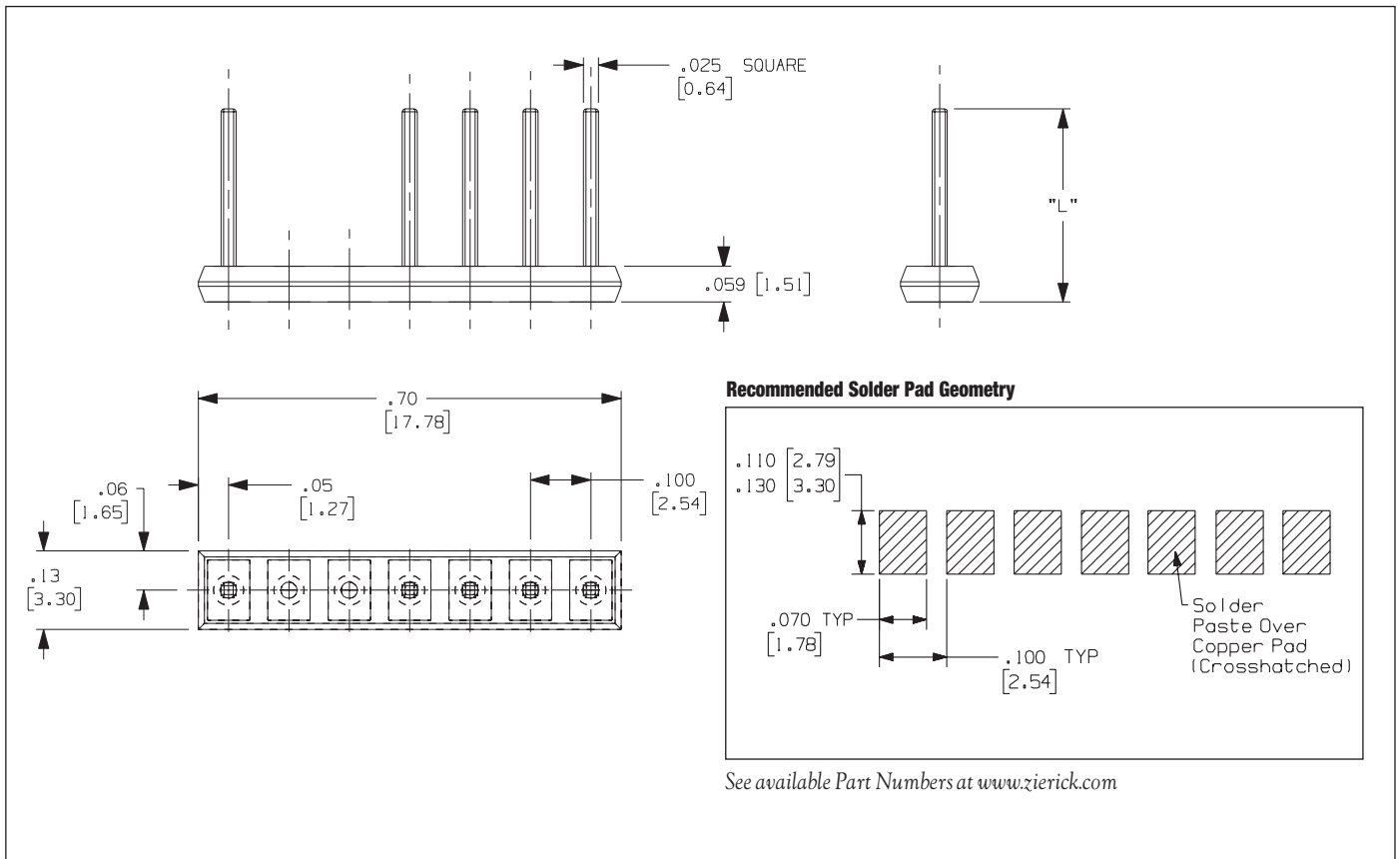

SMT Variable Length Headers

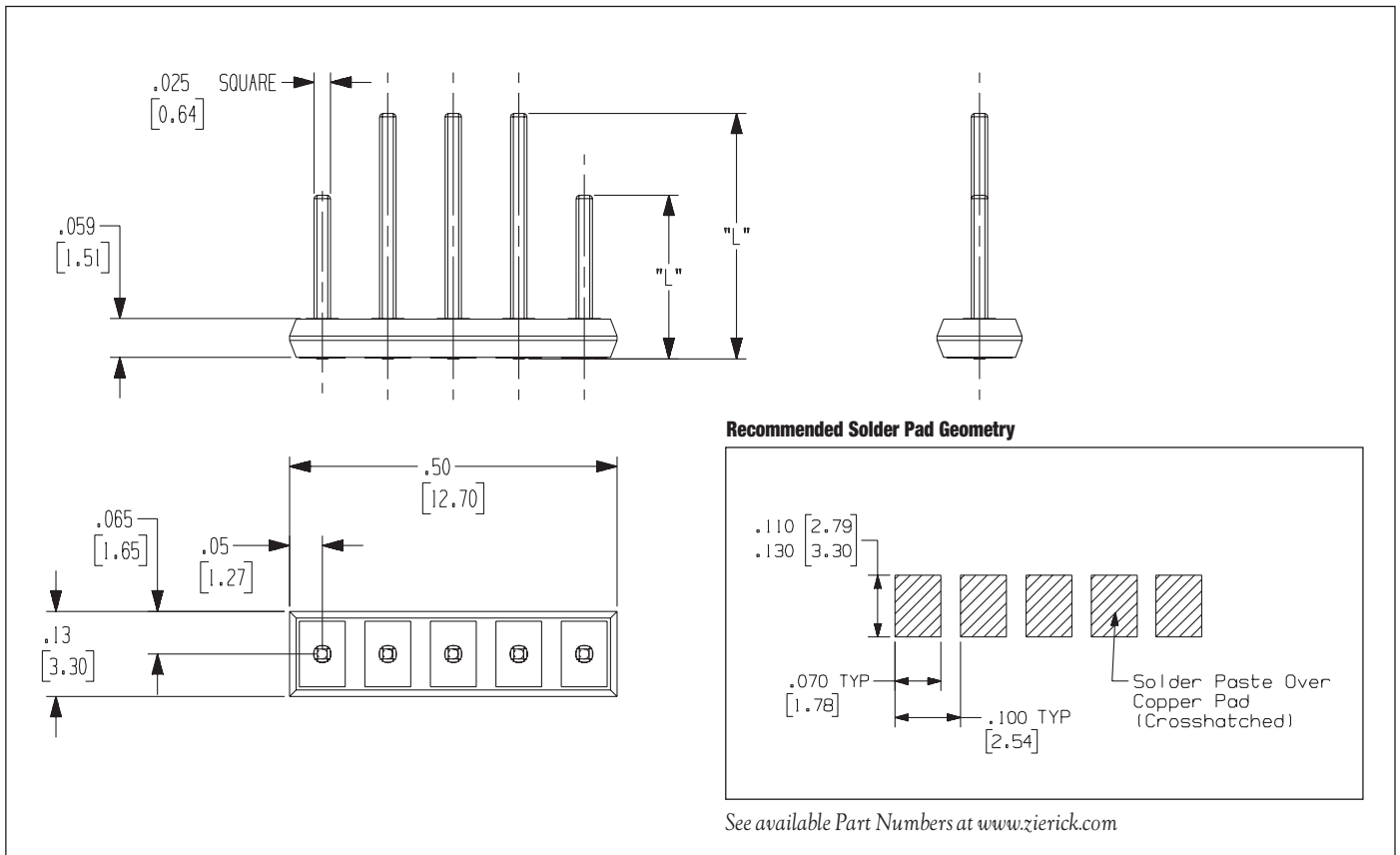

Features and Benefits

- Connectors can be made to different lengths and diameters.
- Self-centering and alignment problems are eliminated.
- Co-planarity is within .001 inch.
- The solder connection and joint strength is superior.
- Parts are available in bulk, pallets or SMT tape.
- The parts are designed for automation using the customer's existing pick and place equipment and a special feeder – no time consuming hand placement or costly fixturing is required.

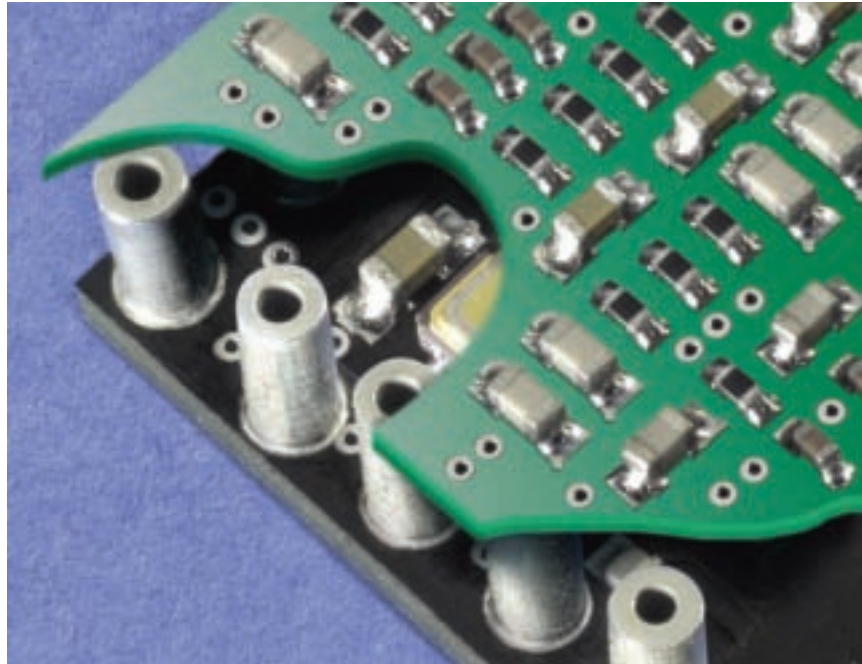

Zierick's Board Stacking Connector allows for more PCB design flexibility and more room for additional components.

Zierick has applied the benefits of capillary action to our Board Stacking Connector. This unique connector surface mounts to both the bottom and the top of a PCB, allowing for the connection of a mother and daughter board without through-hole pins. The result is greater PCB design flexibility, more cost-efficiency and a higher quality connection.

Available in bulk or on SMT tape, the Board Stacking Connectors use minimal real estate, allowing additional components to be placed on the PCB. They are self-centering and offer co-planarity within 0.001", virtually eliminating any alignment problems. Plus, they have low contact resistance and a high current rating to meet today's modular power requirements.

The Board Stacking Connector uses capillary action to provide superior solder joint strength for a more reliable connection. The connectors are first surface-mounted to the mother board. After reflow the PCB with the connectors are surface-mounted to the daughter board.

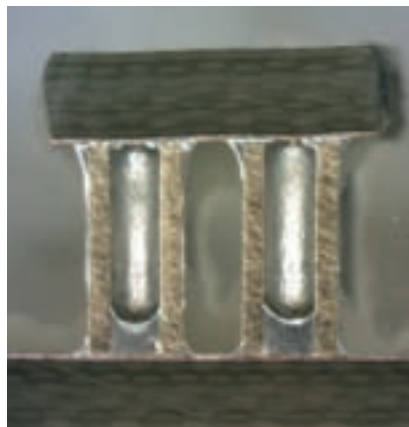

The Board Stacking Connector joins the mother and daughter board with surface mount technology on both boards.

Part Numbers

**1258-090-0, 1258-090-0-TH
1258-090-0-TH-SR,
1258-100-0, 1258-118-0,
1258-118-0-T, 1258-140-0,
1258-157-0, 1258-181-0
1258-197-0, 1258-236-0**

Zierick recommends .006" stencil thickness for most applications. For other stencil thicknesses, call Zierick's product development department.

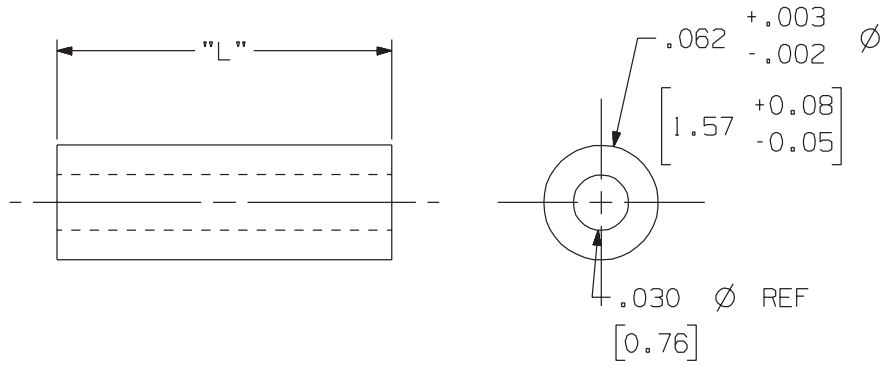

Recommended Solder Pad Geometry for Vertical Placement

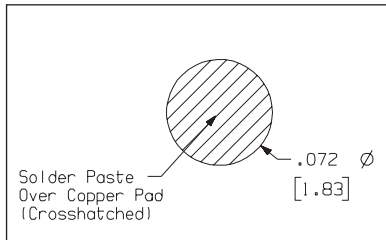

Recommended Solder Pad Geometry for Horizontal Placement

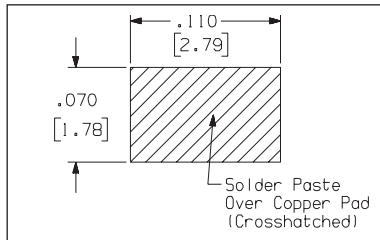

SMT Application

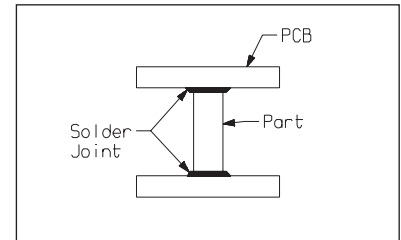

Loose Part No.	1258-090-0	1258-100-0	1258-118-0	1258-140-0	1258-157-0	1258-181-0	1258-197-0	1258-236-0
Taped Part No.	1258-090-0-TH 1258-090-0-TH-SR	n/a	1258-118-0-T	n/a	n/a	n/a	n/a	n/a
Dimensions	.062 x .090 long cylinder	.062 x .100 long cylinder	.062 x .118 long cylinder	.062 x .140 long cylinder	.062 x .157 long cylinder	.062 x .181 long cylinder	.062 x .197 long cylinder	.062 x .236 long cylinder
Finish Material	.000150" Min 100% Tin over .000100" Copper							
Contact Material	C36000 Brass Cylinder Consult factory for optional materials.							
Termination Retention Force	3.5 lbs per terminal							
Current Rating	10 Amperes							

Other lengths may be available. Please consult factory.

Sample Board



Board Stacking Connectors in Trays

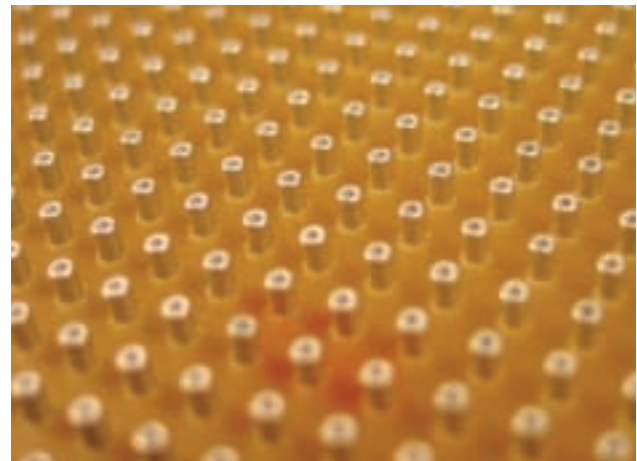

Features and Benefits

- This product features four wire housing holes and four individual piercing blades that can accommodate from 32 to 26 AWG solid, stranded, or tinsel wire.
- It eliminates the need to solder wires to the PCB.
- Four wires can be terminated simultaneously without being stripped first.
- A more durable wire connection is assured.
- The Fine Wire Connector uses minimal PCB real estate.
- The plastic housing resists high reflow temperatures and provides excellent wire protection.
- It can be automatically fed using standard tape and reel.

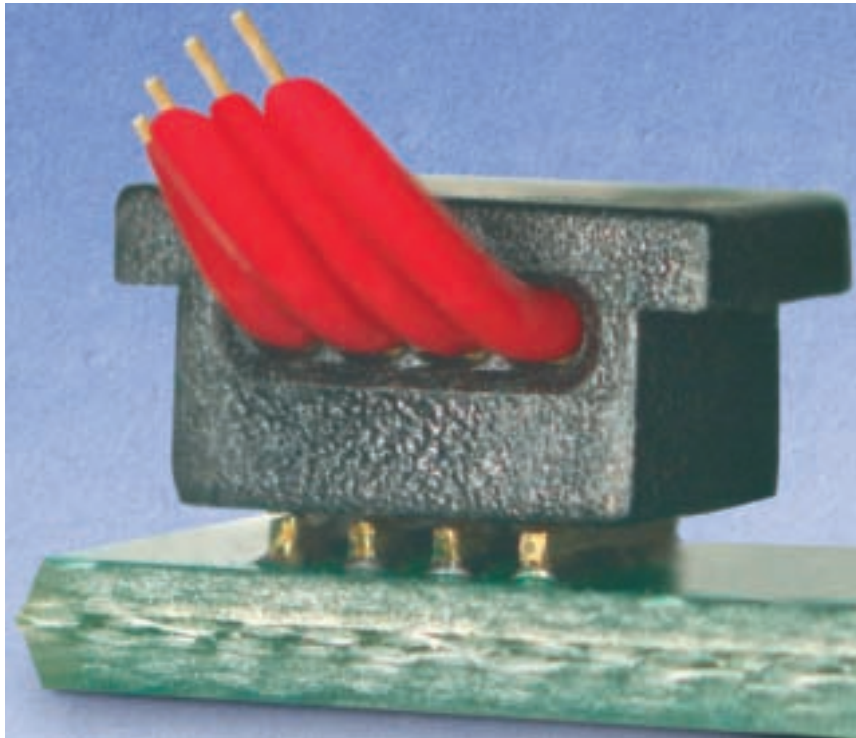

Another product in Zierick's growing line of insulation piercing connectors is the Surface Mount Fine Wire Connector. This connector offers a cost-efficient, reliable solution for solid, stranded or tinsel wire terminations. By allowing reliable one-step multiple wire termination within a plastic housing, the connector reduces assembly costs and provides a more durable wire connection.

Design

Zierick's Fine Wire Connector design builds on Insulation Piercing Connector (IPC) technology, which is the ideal method for wire termination. IPC technology allows multiple wires to be terminated simultaneously without being stripped first. This fine wire IPC connector features

a unique design of four wire housing holes and four individual piercing blades that can accommodate solid, stranded or tinsel wire. The piercing blades are made to go in one direction only and maintain a continuous force on each wire. Its durable plastic housing provides excellent wire retention.

Assembly Process

First, these IPC connectors are surface mounted to the PCB. After reflow, the insulated wires are inserted into the holes of the housing. Force is then applied to the top of the plastic housing and the piercing blades cut through the insulation and penetrate into the wire core—completing the wire connection process.



Zierick's Fine Wire Connectors can efficiently terminate a number of wires all at once. The reliability of the connector assures wire retention and eliminates the need to solder wires directly to the PCB. The piercing blades accommodate solid, stranded or tinsel wire, and are designed to maintain a continuous force on each wire.

**Part Numbers
IPC-4-35, IPC-4-35-T,
IPC-4-35-T-SR,
IPC-4-45, IPC-4-45-T,
IPC-4-45-T-SR**

Zierick recommends .006" stencil thickness for most applications. For other stencil thicknesses, call Zierick's product development department.

Physical	
Loose Part No.	IPC-4-35 IPC-4-45
Taped Part No.	IPC-4-35-T IPC-4-45-T
Small Reel Part No.	IPC-4-35-T-SR IPC-4-45-T-SR
Wire Accommodation	From 32 AWG to 28 AWG solid, stranded or tinsel wire; with insulation diameter of 0.025" - 0.032" From 32 AWG to 26 AWG solid, stranded or tinsel wire; with insulation diameter of 0.033" - 0.043" IPC-4-45 has an ID chamfer in the plastic housing.
Contact Plating	0.000150" Min 100% Tin over .000100 Min Copper
Termination Force	Approx. 80 lbs (for 4 wire)
Insulation Material	PPS GS-40 40% glass filled
Contact Material	CDA 260 Brass
UL Flammability Rating	94V-0
Electrical	
Current Rating/Wire Size	28 AWG 2 Amp., 30-32 AWG 2 Amp.
Insulation Resistance	> 1 x 10 ⁹ Ω @ 500 VDC
Contact Resistance	< 20 mΩ
Withstanding Voltage	500 VRMS @ Sea Level
Environmental	
Reflow Temperature	500°F Max, 260°C Max
Operating Temperature	-67°F to 221°F, (-55°C to 105°C)
U.S. Patent No. 7,320,616	

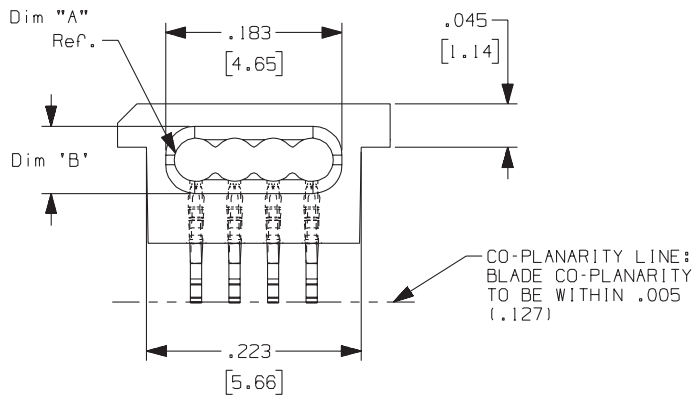
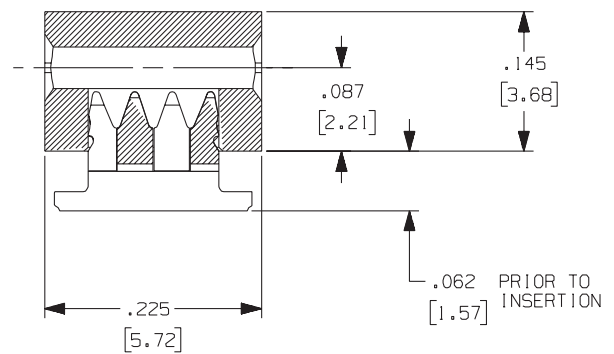
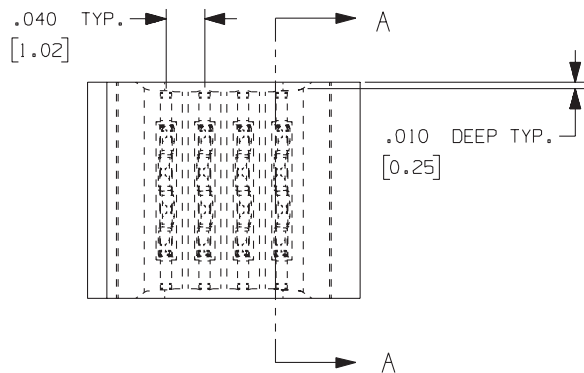

Recommended Solder Pad Geometry

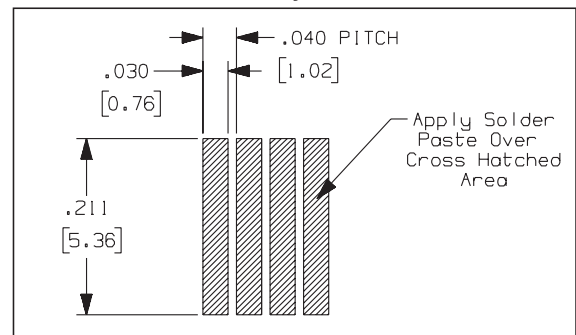

Features and Benefits

- IDCs are designed for demanding applications with shock, vibration, and elevated temperatures.
- The need for hand soldering wires to the board is eliminated.
- They are a surface mount version of a proven through-hole IDC.
- They have a low profile.
- They terminate a large range of wire gauges.
- IDCs don't float during reflow.
- Zierick's IDCs are designed for automation using the customer's existing pick and place equipment and a standard tape feeder.

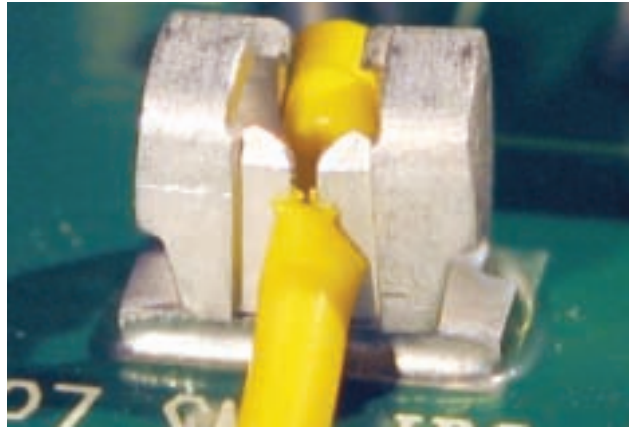

Zierick's Surface Mount IDC was designed to be a more cost effective way to terminate a wire because it eliminates the need for hand

soldering wires to the PCB. It was also designed to be automated by the customer's existing pick and place equipment using standard taping methods. This is a surface mount version of a proven through-hole connector. It is re-usable, has a low profile, and is geographically stable. Our family of SMT IDCs can terminate a large range of stranded or solid wire gauges.

It has a proven track record for withstanding shock and vibrations associated with automotive applications.

The Reverse Mount IDC was designed for through-board applications where the wires must be connected on the side opposite the other components on the PCB.

Part Numbers 1227, 6227

Zierick recommends .006" stencil thickness for most applications. For other stencil thicknesses, call Zierick's product development department.

Loose Part No.	1227
Reeled Part No.	6227
Material Thickness / Type	0.032" (0.81mm) Brass
Standard Finish	100% Tin over Copper
Current Rating	20 Amperes
Feeder System	Surf-Shooter SMT™ Continuous Strip Feeder
Wire Gauge Range	#26-18 AWG Wire insertion tool required. Consult factory.
	U.S. Patent No. 5,695,348 and other international patents

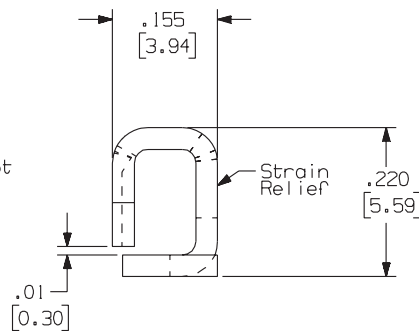
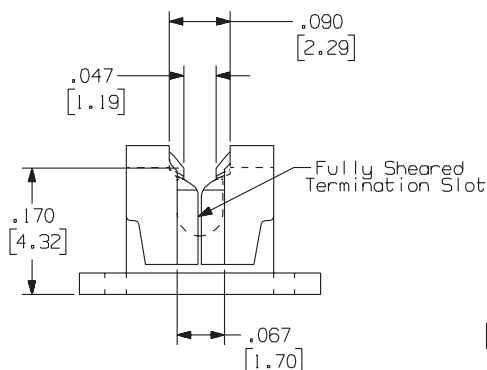
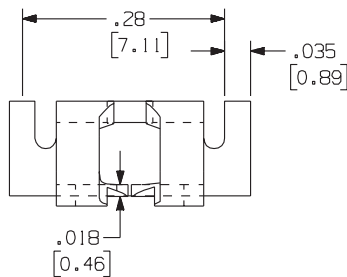

Recommended Solder Pad Geometry

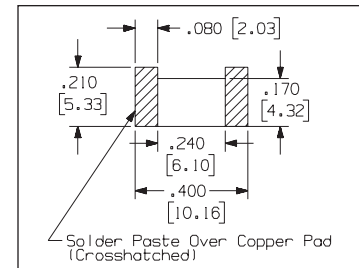

Actual Use

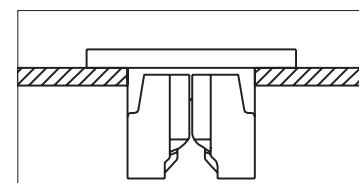

Part Numbers
1235, 1235T, 1235T-SR

Zierick recommends .006" stencil thickness for most applications. For other stencil thicknesses, call Zierick's product development department.

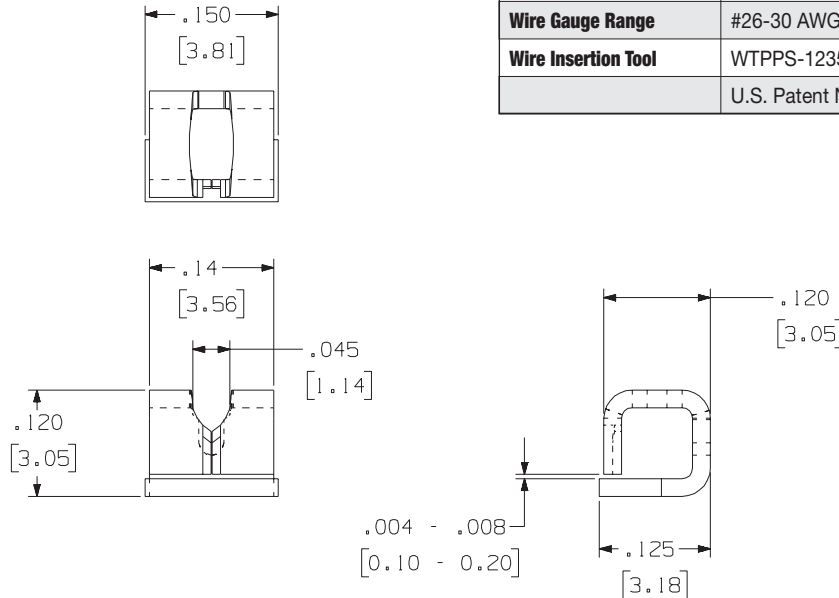

Loose Part No.	1235	
Taped Part No.	1235T	1235T-SR
Material Thickness / Type	0.020" (0.51mm) Brass	
Standard Finish	100% Tin over Copper	
Current Rating	20 Amperes	
Feeder System	N/A	Standard 12mm Tape Feeder
Wire Gauge Range	#26-30 AWG	
Wire Insertion Tool	WTPPS-1235-1: Pnuematic Production Tool	
	U.S. Patent No. 5,695,348 and other international patents	

Recommended Solder Pad Geometry

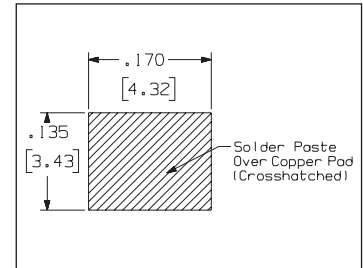

For drawings of our taped parts, please search for this part number on our website, www.zierick.com.

Part Numbers
1245, 1245T, 1245T-SR, 1296, 1296T

Zierick recommends .006" stencil thickness for most applications. For other stencil thicknesses, call Zierick's product development department.

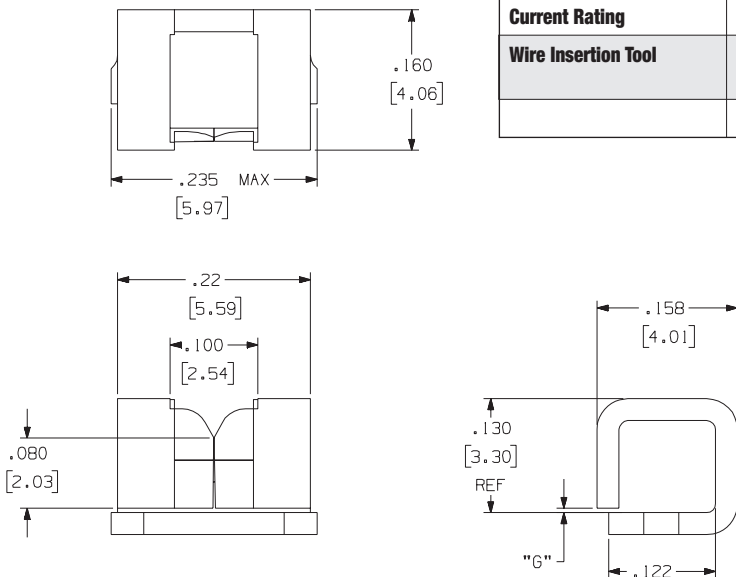

Loose Part No.	1245	1296	
Taped Part No.	1245T	1245T-SR	1296T
Gap Dimension "G"	0.005" (0.13mm)	0.005 - 0.013" (0.13 - 0.33mm)	
Material Thickness / Type	0.025" (0.64mm) Brass		
Standard Finish	100% Tin over Copper		
Feeder System	Standard 12mm Tape Feeder		
Wire Gauge Range	#26-18 AWG		
Current Rating	10 Amperes		
Wire Insertion Tool	WTP-4ALL: Prototype Tool WTPPS-1208-1: Pnuematic Production Tool		
	U.S. Patent No. 5,695,348 and other international patents		

Recommended Solder Pad Geometry

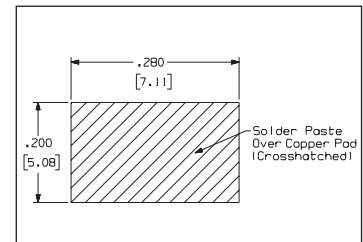

For drawings of our taped parts, please search for this part number on our website, www.zierick.com.

Features and Benefits

- This Zierick product is the most economical way to terminate wire to a surface mount board.
- It has a very small footprint.
- It is capable of carrying high current.
- No separate strain relief is required.
- It has a high resistance to wire flexing and axial and radial pull forces.
- It lends itself to high speed automated termination.
- Designed to be bulk fed with a special feeder, thus eliminating the need for costly taping.
- It is also available in taped format for low volume users.



This method of termination combines the advantages of crimping, insulation piercing, and surface mount technology into a highly reliable and economical way to terminate wires. The system consists of a surface mount terminal and a crimping machine which makes the termination.

The terminal has a flat base and two side walls perpendicular to the base. Two insulation piercing

contact spikes protrude from the flat base. Between the contact spikes there is a flat area to facilitate vacuum pick-up and terminal placement. There are two deep score lines near the transition area between the side wall and the base of the terminal.

Compared to conventional methods, this system is less expensive than a two piece pin/socket connection or an IDC (*insulation displacement*

connector) type of connection which provides strain relief. It is also more cost effective than soldering wires to a board by hand. In comparison, it also takes up very little area on the pcb.

The utilization of well proven crimping and insulation piercing technology guarantees the long term reliability of this connection.

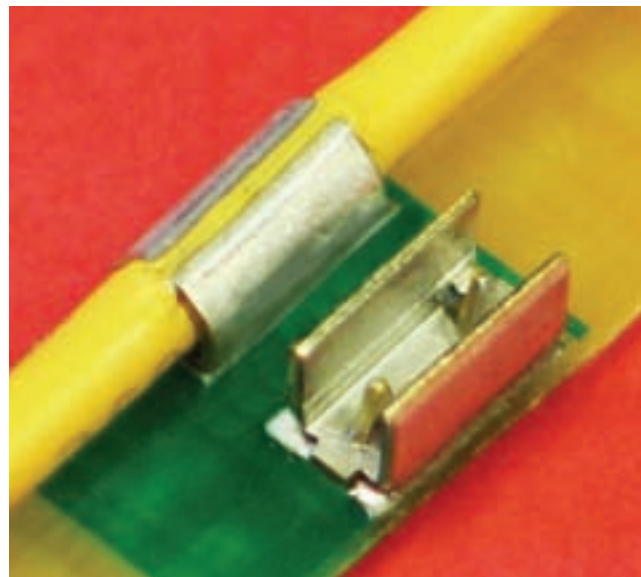
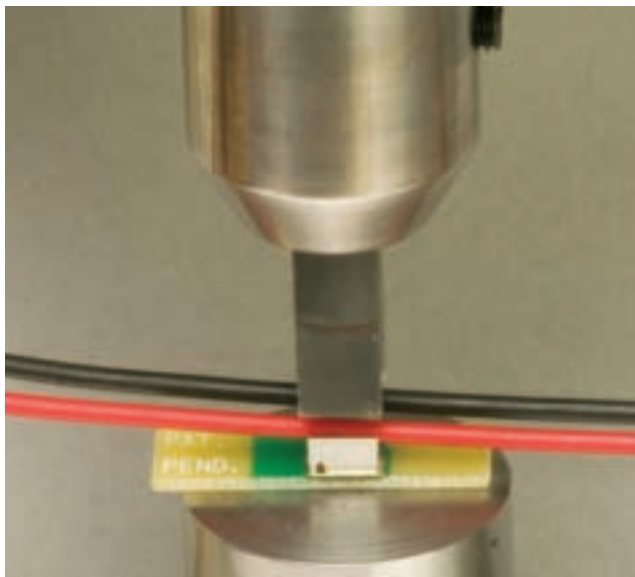

**Part Numbers
1293, 1293T, 1293T-SR**

Zierick recommends .006" stencil thickness for most applications. For other stencil thicknesses, call Zierick's product development department.

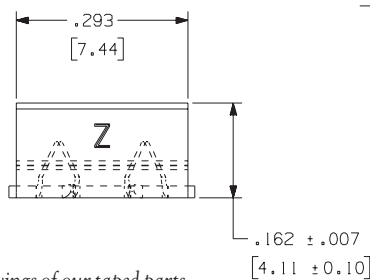
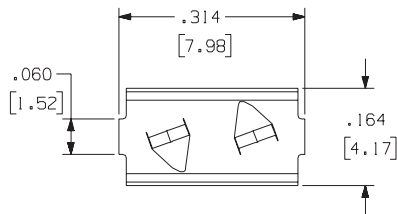

For drawings of our taped parts, please search for this part number on our website, www.zierick.com.

Loose Part No.	1293		
Taped Part No.	1293T		
Small Reel Part No.	1293T-SR		
Wire Sizes (For Stranded Wire)	12 AWG	14 AWG	16 AWG
(Insulation Outside Diameter)	.125 in.	.111 in.	.130 in.
Material Thickness / Type	0.020" (0.51mm) Pre-Plated Brass		
Standard Finish	Pre-finished 100% Matte Tin over Copper. Edges will be bare.		
Feeder System	Standard 16mm Tape Feeder for PN 1293T		
Crimping System	Mini Press (for high volume applications) Versa-Crimp (for low volume applications) WTC-1293-1 (for low volume and/or field terminations)		
	U.S. Patent No. 7,591,666 B2 and other U.S. and international patents		

Recommended Solder Pad Geometry

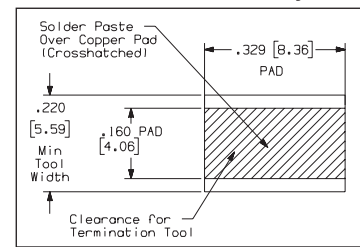

Note: For side by side placement consult factory for center-to-center spacing.

**Part Numbers
1286, 1286T, 1286T-SR**

Zierick recommends .006" stencil thickness for most applications. For other stencil thicknesses, call Zierick's product development department.

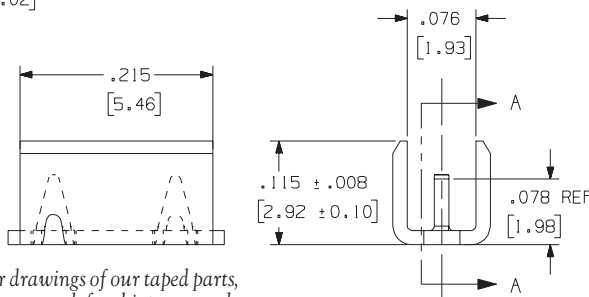
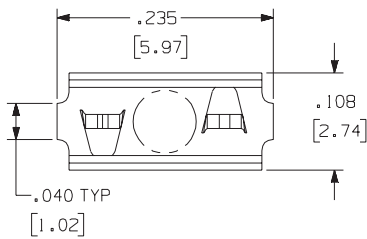

For drawings of our taped parts, please search for this part number on our website, www.zierick.com.

Loose Part No.	1286						
Taped Part No.	1286T						
Small Reel Part No.	1286T-SR						
Wire Sizes (For Stranded Wire)	16 AWG	18 AWG					20 AWG
(Insulation Outside Diameter)	.077 in.	.068 in.	.078 in.	.080 in.	.068 in.	.073 in.	.082 in.
Material Thickness / Type	0.016" (0.41mm) CDA 260 Brass						
Standard Finish	Pre-finished 100% Matte Tin over Copper. Edges will be bare.						
Feeder System	Standard 12mm Tape Feeder for PN 1286T						
Crimping System	Mini Press (for high volume applications) Versa-Crimp (for low volume applications) WTC-1286-1 (for low volume and/or field terminations)						
	U.S. Patent No. 7,591,666 B2 and other U.S. and international patents						

Recommended Solder Pad Geometry

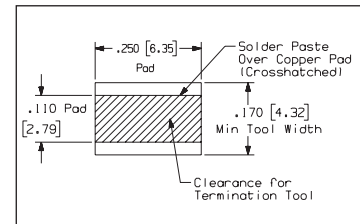

Note: For side by side placement consult factory for center-to-center spacing.

Part Numbers 1295, 1295T, 1295T-SR

Zierick recommends .006" stencil thickness for most applications. For other stencil thicknesses, call Zierick's product development department.

For drawings of our taped parts, please search for this part number on our website, www.zierick.com.

Loose Part No.	1295				
Taped Part No.	1295T				
Small Reel Part No.	1295T-SR				
Wire Sizes (For Stranded Wire)	20 AWG			22 AWG	
(Insulation Outside Diameter)	.045 in.	.050 in.	.061 in.	.053 in.	.058 in.
Material Thickness / Type	0.012" (0.30mm) Pre-Plated Brass				
Standard Finish	Pre-finished 100% Matte Tin over Copper. Edges will be bare.				
Feeder System	Standard 16mm Tape Feeder				
Crimping System	Mini Press (for high volume applications) Versa-Crimp (for low volume applications) WTC-1295-1 (for low volume and/or field terminations)				
	U.S. Patent No. 7,591,666 B2 and other U.S. and international patents				

Recommended Solder Pad Geometry

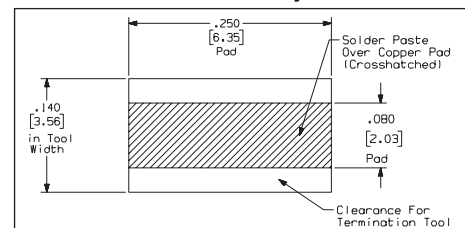

Note: For side by side placement consult factory for center-to-center spacing.

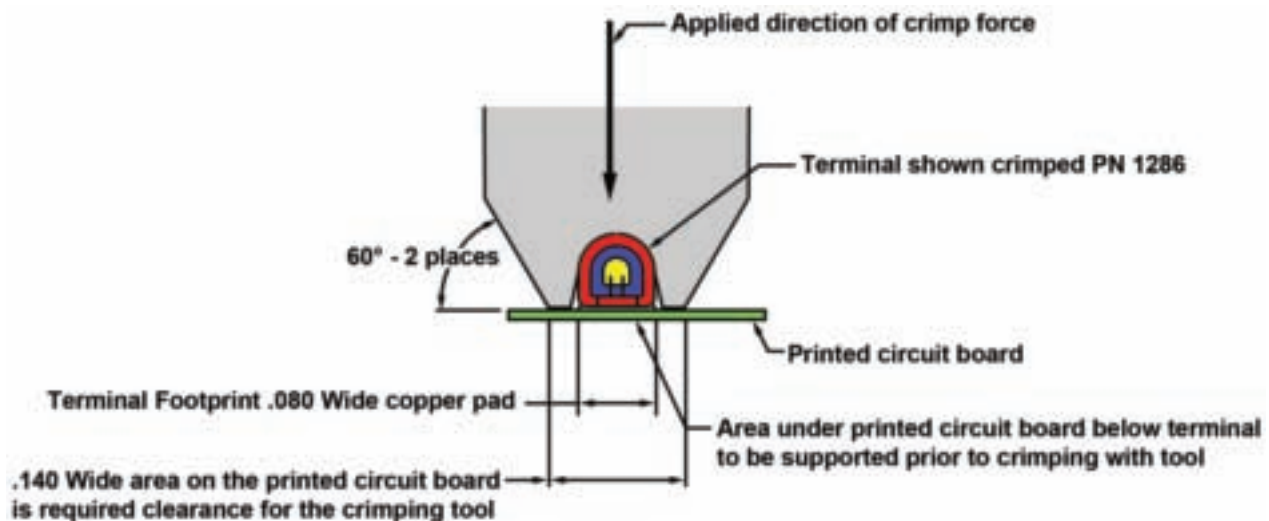
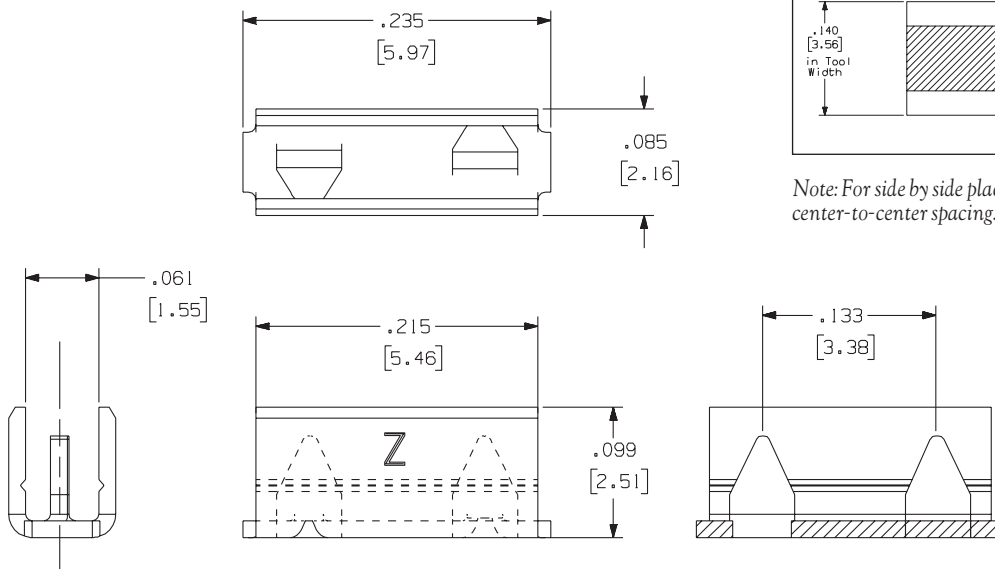

**Part Number
1300-T**

Features and Benefits

- This Zierick product is one of the most economical ways to terminate wire to a surface mount board.
- Part placement can be automated.
- It has high resistance to shock and vibration.
- There is no need to strip the cord.
- The wire is terminated by using a Zierick crimping press.
- The part is available in taped format.

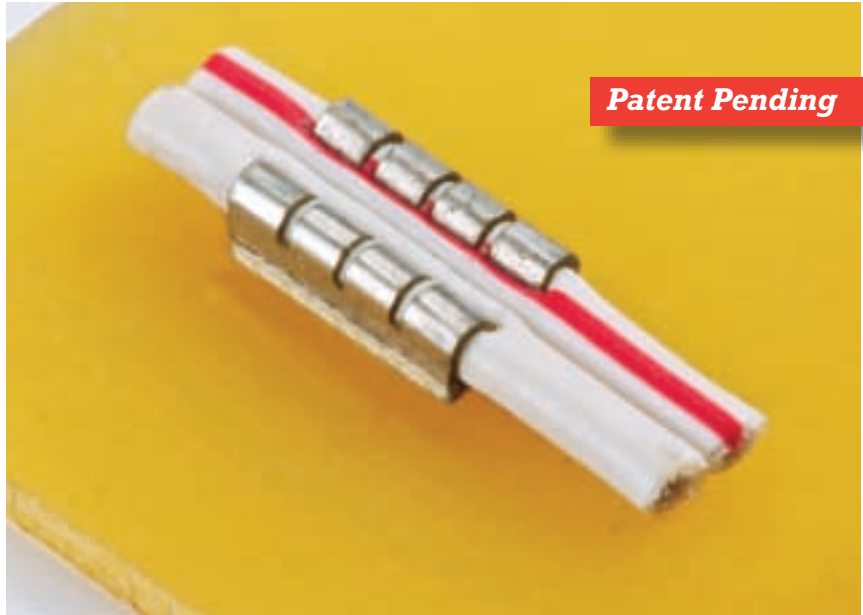

This Surface Mount Zip Cord connector is comprised of two identical parts, turned so the connector spikes face each other. The parts are held in the correct configuration for the AWG of the Zip Cord, and placed in Tape Pockets for easy nozzle pick-up.

Taped Part No.	1300-T
Wire Size	Approximately .100"x.200" 18 AWG paired conductor wire
Material Thickness / Type	.012 CDA-260 Brass
Standard Finish	Pre-finished 100% Matte Tin over Copper. Edges will be bare.
Crimping System	MP-1000 Crimping Machine (for high volume applications) Versa-Crimp (for low volume applications)
Feeder System	Standard 24mm Tape Feeder

Zierick recommends .006" stencil thickness for most applications.
For other stencil thicknesses, call Zierick's product development department.

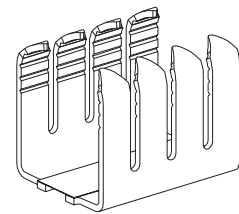
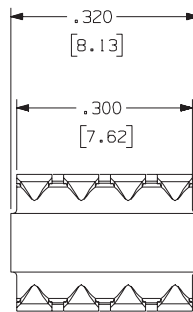

Because of the variations of the outside diameter of the insulation and the diameter of the conductor, it is highly recommended that each wire be tested to insure a proper connection to the wire. Current rating is dependent on wire sizes. Consult factory. See the website for all pad layouts and new part numbers for different wire gauges.

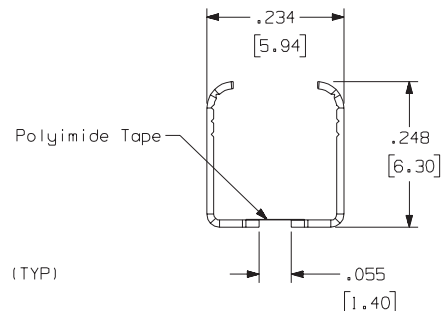
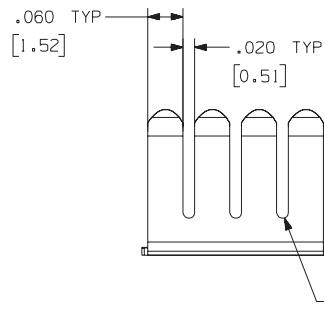

Part Numbers 1302, 1302-2-HDR, 1302-2-HDR-T, 6302

Patent Pending



Features and Benefits

- This Zierick product is one of the most economical ways to terminate wire to a printed circuit board.
- Part placement can be automated.
- It has high resistance to shock and vibration.
- There is no need to strip the wire.
- The wire is terminated by using a Zierick crimping press.
- It is also available in taped format and taped header format for low volume users.

Loose Part No.	1302	1302-2-HDR
Reeled Part No.	6302	
Taped Part No.	1302-2-HDR-T	
Wire Size	Approximately .100" Thick x .200" Wide	
Material Thickness / Type	.020 CDA-260 Brass	
Standard Finish	Pre-finished 100% Matte Tin over Copper. Edges will be bare.	
Feeder System	SMT Feeder for Loose Piece Terminals Standard 16mm Tape Feeder	
Crimping System	MP-1000 Crimping Machine (for high volume applications) Versa-Crimp (for low volume applications)	

Zierick recommends .006" stencil thickness for most applications.
For other stencil thicknesses, call Zierick's product development department.

This Surface Mount Zip Cord connector is comprised of two identical parts, turned so the connector spikes face each other. The parts are placed into plated through-holes and can be used in either a conventional Surface Mount or Through-Hole Technology process.

In the Surface Mount process, a Zierick feeder can separate one part from a strip of parts and present each to a pick and place machine using a gripper. For Through-Hole applications, a Zierick THT Assembly System can quickly insert these parts directly onto the PCB. The utilization of well proven crimping and insulation piercing technology guarantees the long term reliability of this connection.



Because of the variations of the outside diameter of the insulation and the diameter of the conductor, it is highly recommended that each wire be tested to insure a proper connection to the wire. Current rating is dependent on wire sizes. Consult factory. See the website for all pad layouts and new part numbers for different wire gauges.

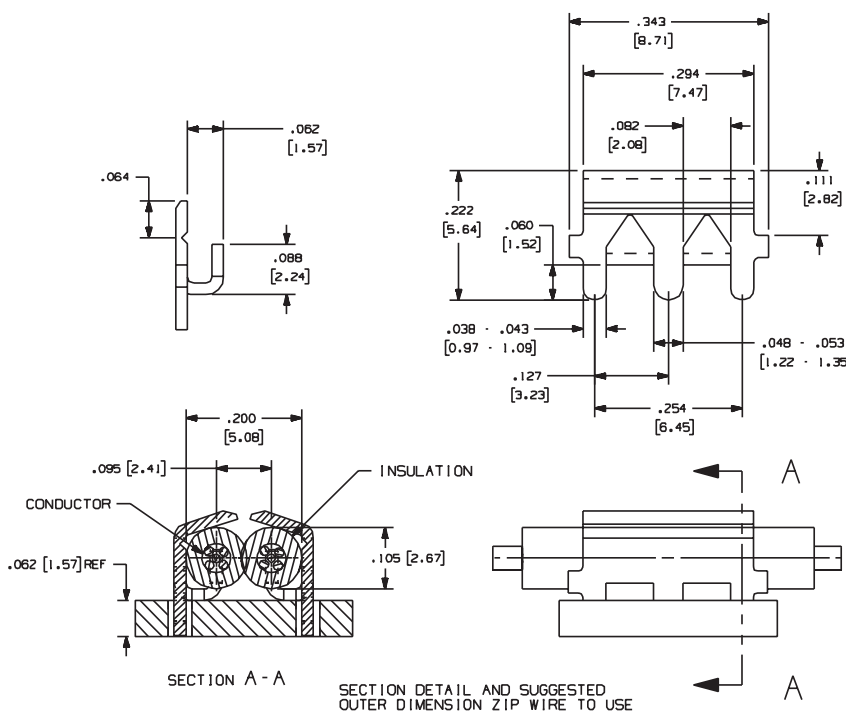

Part Numbers
1262, 6262, 1262T,
1262T-SR, 1262TH

Zierick recommends .006" stencil thickness for most applications. For other stencil thicknesses, call Zierick's product development department.

Loose Part No.	1262		
Reeled Part No.	6262		
Taped Part No.	1262T	1262T-SR	1262TH
Mating Terminal Size	0.025" (0.64mm) square or 0.032" (0.81mm) round pin		
Material Thickness / Type	0.010" (0.25mm) Phosphor Bronze		
Standard Finish	100% Tin over Copper		
Current Rating	20 Amperes		
Feeder System	Surf-Shooter SMT™ Continuous Strip Feeder Standard 24mm Tape Feeder for PN 1262T and PN 1262TH		

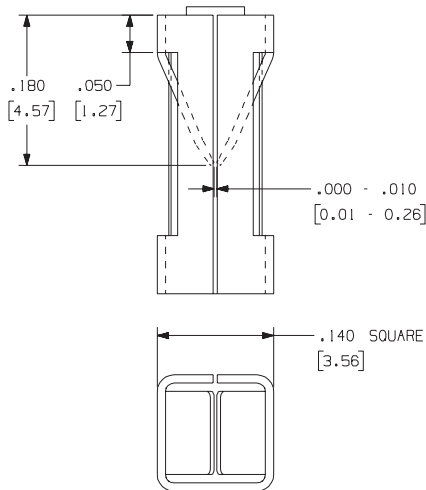
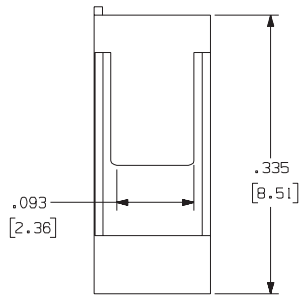

Recommended Solder Pad Geometry for Horizontal Mount

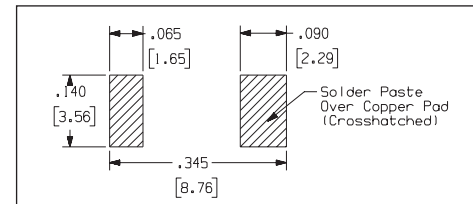

Recommended Solder Pad Geometry for Vertical Mount

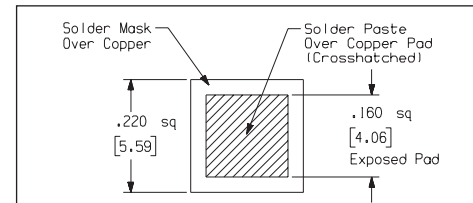

For drawings of our taped parts, please search for this part number on our website, www.zierick.com.

Part Numbers
1301, 1301TH, 6301

Zierick recommends .006" stencil thickness for most applications. For other stencil thicknesses, call Zierick's product development department.

Loose Part No.	1301
Reeled Part No.	6301
Taped Part No.	1301TH
Mating Terminal Size	0.025" (0.64mm) square or 0.025" (0.64mm) round pin
Material Thickness / Type	.008" (0.20mm) Phosphor Bronze
Standard Finish	100% Tin over Copper
Current Rating	10 Amperes
Feeder System	Surf-Shooter SMT™ Continuous Strip Feeder Standard 24mm Tape Feeder for PN 1301TH

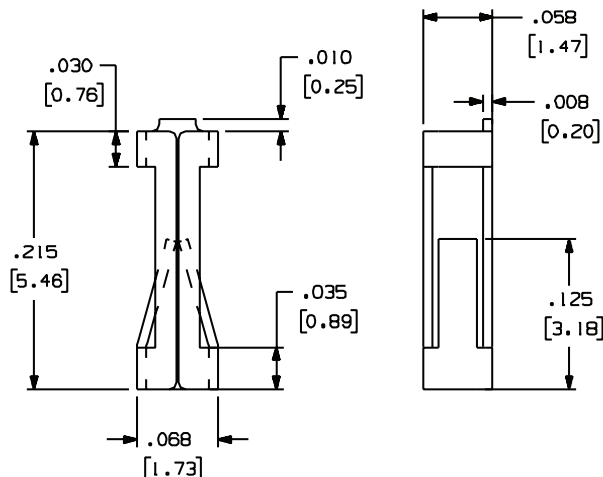

Recommended Solder Pad Geometry

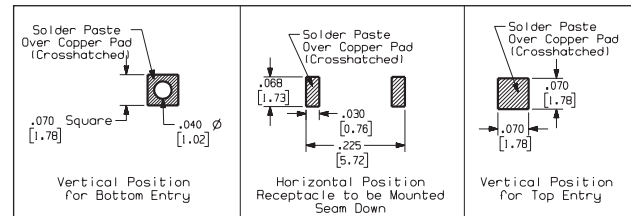

For drawings of our taped parts, please search for this part number on our website, www.zierick.com.

Part Numbers 1179, 1179T, 1179T-SR, 6179

Zierick recommends .006" stencil thickness for most applications. For other stencil thicknesses, call Zierick's product development department.

Loose Part No.	1179	1179T	1179T-SR
Reeled Part No.	6179	N/A	
Material Thickness / Type	0.020" (0.51mm) CDA 11000 Copper		
Standard Finish	100% Tin over Copper		
Current Rating	25 Amperes		
Feeder System	Surf-Shooter SMT™ Continuous Strip Feeder	Standard 24mm Tape Feeder	

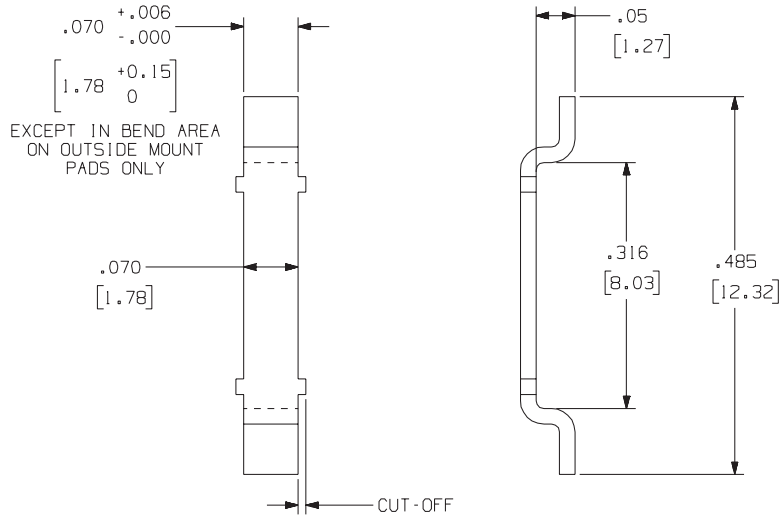

Recommended Solder Pad Geometry

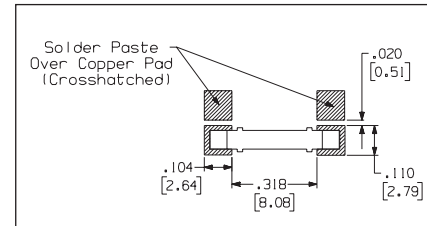

For drawings of our taped parts, please search for this part number on our website, www.zierick.com.

Part Numbers 6233-001, 6233-002, 6233-310-140, 6233-585-200, 6233-787-140, 6233-787-140-T

Zierick recommends .006" stencil thickness for most applications. For other stencil thicknesses, call Zierick's product development department.

Reeled Part No.	6233-001	6233-002	6233-310-140	6233-585-200	6233-787-140
Taped Part No.	6233-787-140-T				
Dim 'A' **	0.300" (7.62mm)	0.485" (12.3mm)	1.500" (38.1mm)	0.585" (14.9mm)	0.787" (20.0mm)
Dim 'B' **	0.075" (1.91mm)	0.075" (1.91mm)	0.075" (1.91mm)	0.200" (5.08mm)	0.140" (3.56mm)
Material Thickness / Type	0.020" (0.51mm) Copper				
Standard Finish	100% Tin Over Copper				
Feeder System	Standard 24mm Tape Feeder				

	Dim 'A' **	Dim 'B' **
Minimum	0.300" (7.62mm)	0.075" (1.91mm)
Maximum	1.500" (38.1mm)	0.200" (5.08mm)

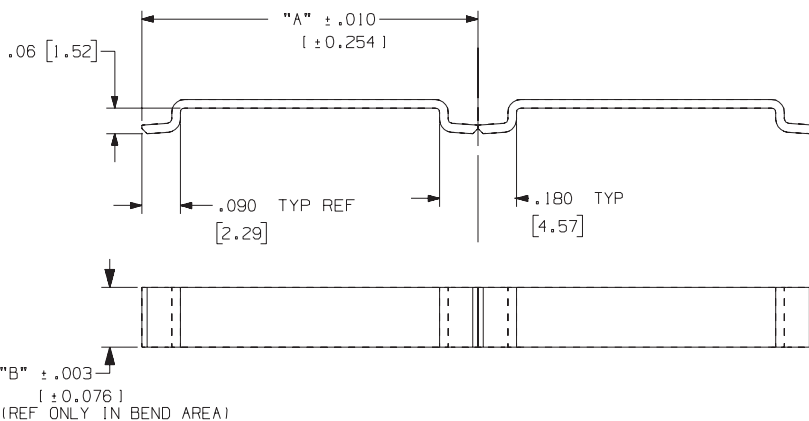

*Where Dimension 'A' = jumper length and Dimension 'B' = jumper width. Different lengths and widths are available. Please consult factory.

Recommended Solder Pad Geometry

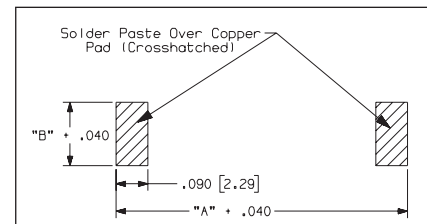

For drawings of our taped parts, please search for this part number on our website, www.zierick.com.

Zierick's family of SMT receptacles provides a range of options designed to lower manufacturing costs, simplify assembly, and increase

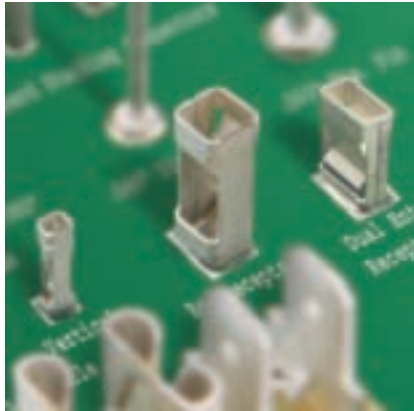

Box Receptacles

productivity. Zierick has expanded its Surface Mount product line to include Universal Tab Receptacles, Box Receptacles, Clips, and Bottom



Fuse Clips

Entry Through-Board Sockets, increasing the options for flexibility and compatibility.

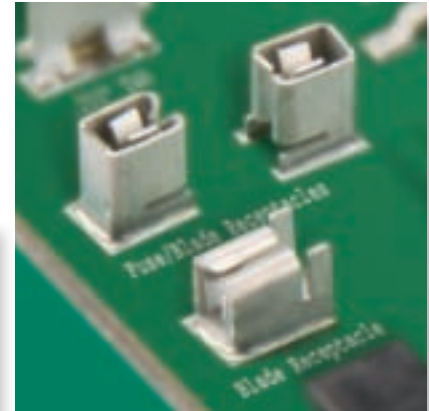

Universal Tab Receptacles Fuse Clips

SMT Universal Tab Receptacles

Features and Benefits

- These receptacles are forgiving for mating misalignment.
- They mate with a range of tabs from .025" to .032" thick and widths from .110" wide and larger.
- They have low insertion forces.
- They have a high current rating of 30 Amps.
- They can have a dozen mating cycles (a higher mating cycle version is available).
- This product performs well in demanding automotive applications (shock, vibration, elevated temperature).
- They may be used for top, bottom, or side entry.



- They are designed for automation using the customer's existing pick and place equipment and a special feeder for a continuous strip of components.

- These parts can also be automatically "picked and placed" from tape and reel.

Part Numbers
1237, 1237T, 1237T-SR,
1237-BMT, 1237-BMT-SR,
1237T-KT,
1237T-KT-SR,
1237-BMT-KT,
1237-BMT-KT-SR,

Zierick recommends .006" stencil thickness for most applications. For other stencil thicknesses, call Zierick's product development department.

Loose Part No.	1237			
Reeled Part No.	6237			
Taped Part No.	1237T 1237T-SR	1237-BMT 1237-BMT-SR	1237T-KT 1237T-KT-SR	1237-BMT-KT 1237-BMT-KT-SR
Mating Terminal Size	0.025" (0.64mm) to 0.032" (0.81mm) thick			
Material Thickness / Type	0.016" (0.41mm) Brass			
Standard Finish	100% Tin over Copper			
Current Rating	25 Amperes			
Feeder System	Consult factory for Surf-Shooter SMT™ Continuous Strip Feeder P/N 6237 Standard 16mm Tape Feeder			

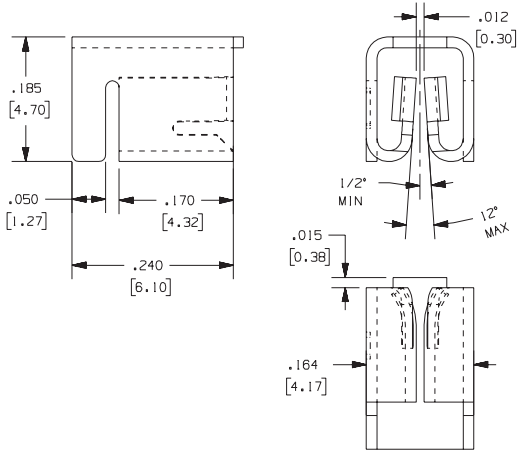

Recommended Solder Pad Geometry

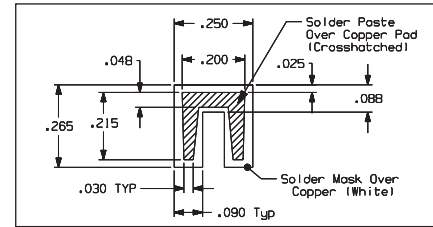

For drawings of our taped parts, please search for this part number on our website, www.zierick.com.

SMT Bottom or Horizontal Entry Universal Tab Receptacles

Part Numbers 1238, 1238T,
1238T-SR, 1238-BMT,
1238T-KT
1238T-KT-SR, 6238

Zierick recommends .006" stencil thickness for most applications. For other stencil thicknesses, call Zierick's product development department.

Loose Part No.	1238		
Reeled Part No.	6238		
Taped Part No.	1238T 1238T-SR	1238-BMT	1238T-KT 1238T-KT-SR
Mating Terminal Size	0.025" (0.64mm) to 0.032" (0.81mm) thick		
Material Thickness / Type	0.016" (0.41mm) Brass		
Standard Finish	100% Tin over Copper		
Current Rating	25 Amperes		
Feeder System	Consult factory for Surf-Shooter SMT™ Continuous Strip Feeder P/N 6238 Standard 16mm Tape Feeder		

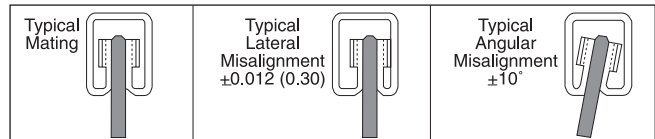
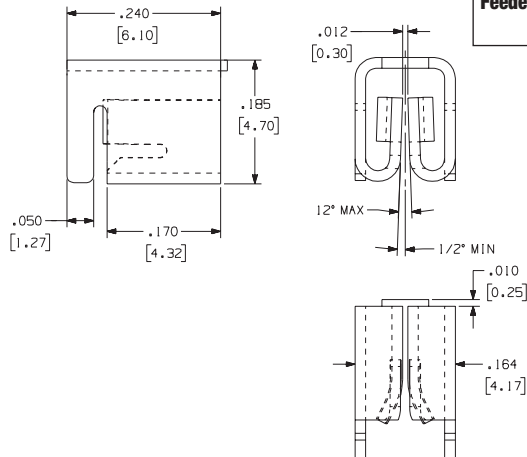

Recommended Solder Pad Geometry

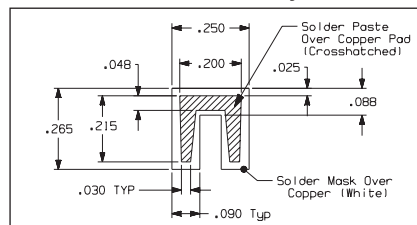

For drawings of our taped parts, please search for this part number on our website, www.zierick.com.

Features and Benefits

- Zierick's Box contacts offer low insertion forces.
- The high pressure contact area assures a reliable gas tight connection.
- They are forgiving for locational misalignment.
- A dozen mating cycles can be expected (a higher mating cycle version is available).
- They use a small footprint.
- These parts are designed for automation using the customer's existing pick and place equipment and a special feeder for a continuous strip of components.
- These parts can also be automatically "picked and placed" from tape and reel.



SMT Dual Entry Box Receptacle

Part Numbers
1266, 6266, 1266-TV,
1266-TV-KT

Zierick recommends .006" stencil thickness for most applications. For other stencil thicknesses, call Zierick's product development department.

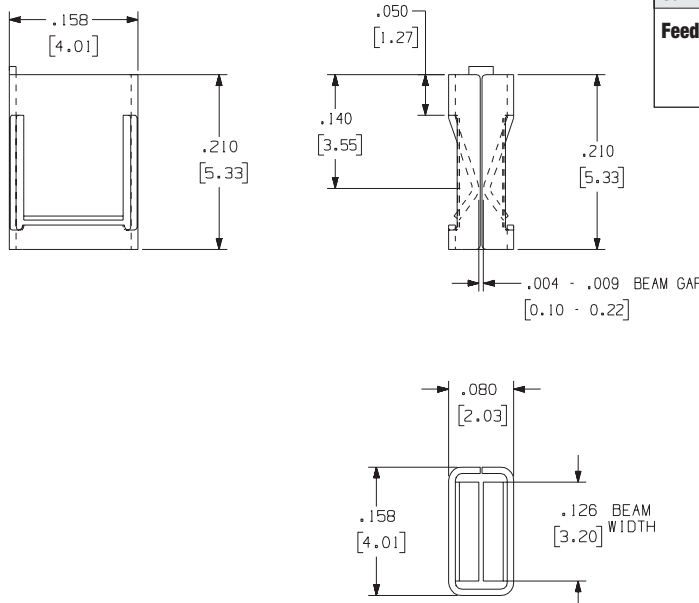

Loose Part No.	1266	
Reeled Part No.	6266	
Taped Part No.	1266-TV	1266-TV-KT
Mating Terminal Size	0.020" (0.51mm) to 0.032" (0.81mm) thick	
Material Thickness / Type	0.008" (0.20mm) Phosphor Bronze	
Standard Finish	100% Tin over Copper	
Current Rating	20 Amperes	
Feeder System	Surf-Shooter SMT™ Continuous Strip Feeder Standard 16mm Tape Feeder for PNs 1266-TV and 1266-TV-KT	

Recommended Solder Pad Geometry

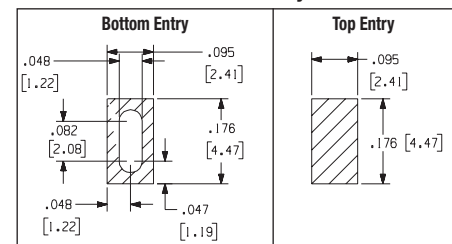

For drawings of our taped parts, please search for this part number on our website, www.zierick.com.

Part Numbers
1262, 6262, 1262T, 1262T-SR, 1262TH

Zierick recommends .006" stencil thickness for most applications. For other stencil thicknesses, call Zierick's product development department.

Loose Part No.	1262		
Reeled Part No.	6262		
Taped Part No.	1262T	1262T-SR	1262TH
Mating Terminal Size	0.025" (0.64mm) square or 0.032" (0.81mm) round pin		
Material Thickness / Type	0.010" (0.25mm) Phosphor Bronze		
Standard Finish	100% Tin over Copper		
Current Rating	20 Amperes		
Feeder System	Surf-Shooter SMT™ Continuous Strip Feeder Standard 12mm Tape Feeder for PN 1262T and PN 1262TH		

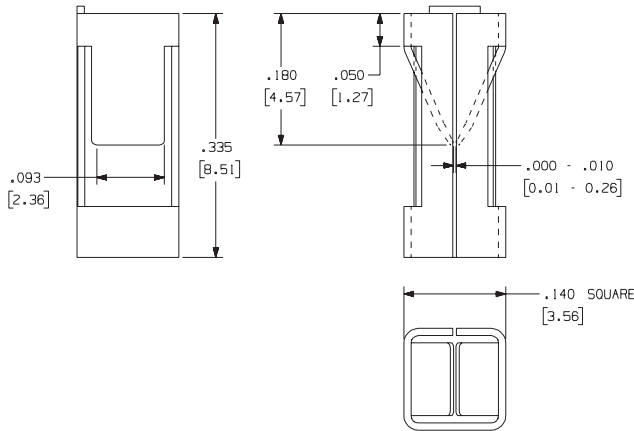

Recommended Solder Pad Geometry For Horizontal Mount

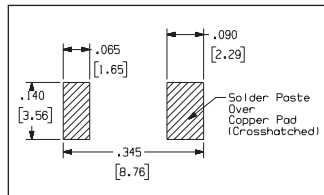

Recommended Solder Pad Geometry For Vertical Mount

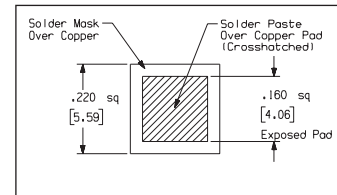

For drawings of our taped parts, please search for this part number on our website, www.zierick.com.

Part Numbers
1301, 1301TH, 6301

Zierick recommends .006" stencil thickness for most applications. For other stencil thicknesses, call Zierick's product development department.

Loose Part No.	1301		
Reeled Part No.	6301		
Taped Part No.	1301TH		
Mating Terminal Size	0.025" (0.64mm) square or 0.025" (0.64mm) round pin		
Material Thickness / Type	.008" (0.20mm) Phosphor Bronze		
Standard Finish	100% Tin over Copper		
Current Rating	10 Amperes		
Feeder System	Surf-Shooter SMT™ Continuous Strip Feeder Standard 24mm Tape Feeder for PN 1301TH		

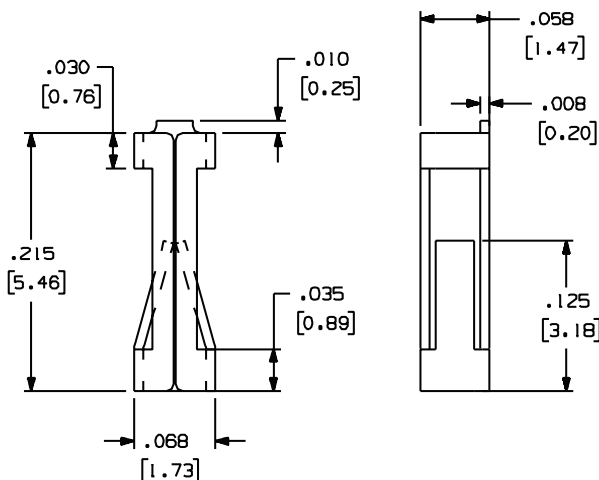

Recommended Solder Pad Geometry

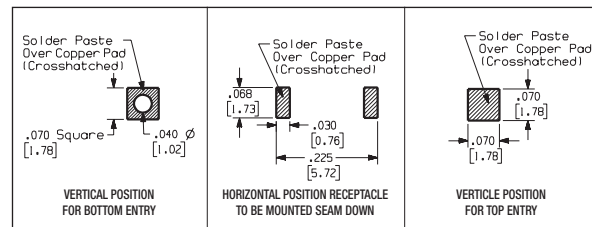

For drawings of our taped parts, please search for this part number on our website, www.zierick.com.

Part Numbers 1277, 6277, 1277-TH, 1277-TH-SR, 1277-TV-G, 1277-TV-G-SR, 1277-TV-N

Zierick recommends .006" stencil thickness for most applications. For other stencil thicknesses, call Zierick's product development department.

Loose Part No.	1277				
Reeled Part No.	6277				
Taped Part No.	1277-TH	1277-TH-SR	1277-TV-G	1277-TV-G-SR	1277-TV-N
Mating Terminal Size	0.025" (0.64mm) square or round pin				
Material Thickness / Type	0.008" (0.20mm) Phosphor Bronze				
Standard Finish	100% Tin over Copper				
Current Rating	10 Amperes				
Feeder System	Loose: Standard 16mm Tape Feeder for PN 1277-TH Reeled: Consult Factory for Feeder Standard 24mm Tape Feeder for PN 1277-TV-G and PN 1277-TV-N				

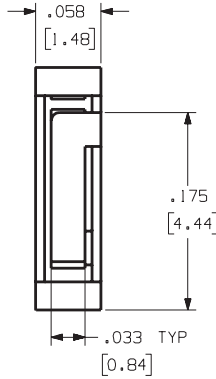
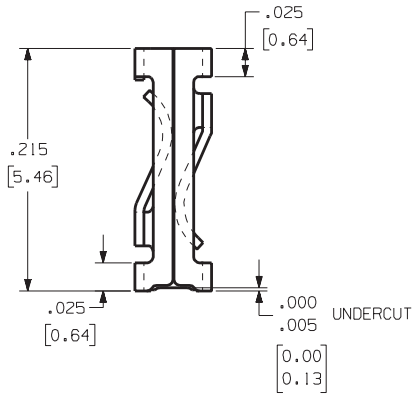

Recommended Solder Pad Geometry

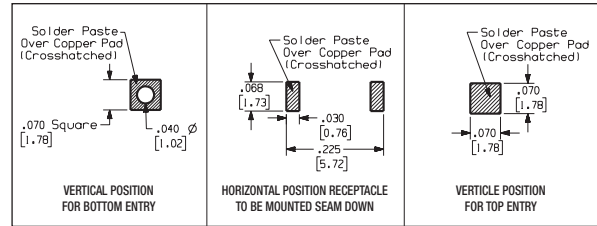

For drawings of our taped parts, please search for this part number on our website, www.zierick.com.

SMT Box Receptacles for High Temp Applications

Part Numbers 1275, 6275, 1275T, 1275TH

Zierick recommends .006" stencil thickness for most applications. For other stencil thicknesses, call Zierick's product development department.

Loose Part No.	1275	
Reeled Part No.	6275	
Taped Part No.	1275T	1275TH
Mating Terminal Size	0.025" (0.64mm) and 0.032" (0.81mm) Round or Square	
Mounting Type	Surface Mount	
Material Thickness / Type	0.010" (0.25mm) CDA 70250 High Performance Alloy	
Standard Finish	Loose: 100% Tin over Copper Reeled: 100% Tin over Copper	
Mating Entry	Top and Bottom	
Current Rating	20 Amperes	
Resistance Rating	10mΩ Max	
Temperature Rating	Up to 175°C	
Feeder System	Surf-Shooter SMT™ Continuous Strip Feeder Standard 24mm Tape Feeder	

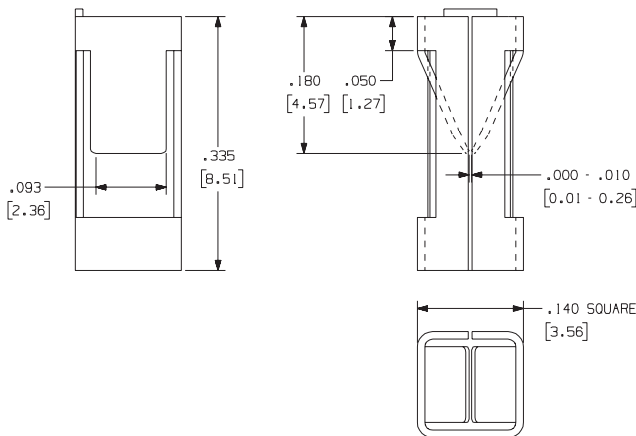

Recommended Solder Pad Geometry

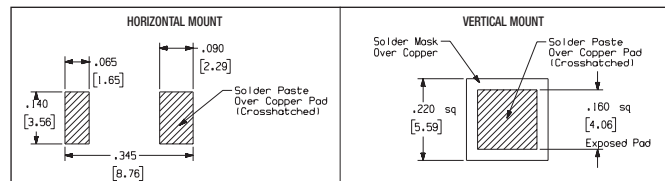

For drawings of our taped parts, please search for this part number on our website, www.zierick.com.

Features and Benefits

- Individual clips can be randomly placed.
- Clips don't float during reflow.
- Clips are available in two gap widths - 0.165" gap for use with standard 5mm fuses and 0.095" gap for use as a 1/8" (.125") pin receptacle.
- The gap dimension / contact force can be optimized for specific applications depending on mating cycles, voltage current and operating environment.
- It has a suitable force for fuse retention.
- Clips are designed for automation using the customer's existing pick and place equipment and a special feeder for a continuous strip of components.
- These parts can also be automatically "picked and placed" from tape and reel.

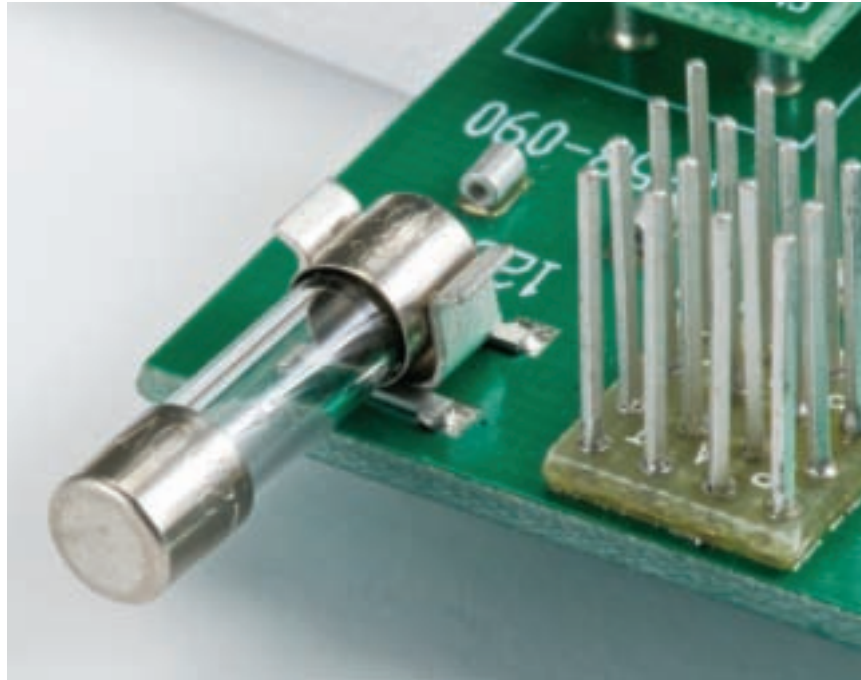

Part Numbers 1230, 1230T, 1230T-SR, 1184, 1184T, 6230, 6184

Zierick recommends .006" stencil thickness for most applications. For other stencil thicknesses, call Zierick's product development department.

	5mm Fuse	Clip Connector
Loose Part No.	1230	1184
Reeled Part No.	6230	6184
Taped Part No.	1230T 1230T-SR	1184T
Dim 'A'	0.165" (4.19mm)	0.090" (2.29mm)
Material Thickness / Type	0.016" (0.41mm) Phosphor Bronze	
Standard Finish	100% Tin over Copper	
Current Rating	15 Amperes	
Feeder System	Surf-Shooter SMT™ Continuous Strip Feeder Standard 16mm Tape Feeder	
	U.S. Patent Nos. 5,695,348, 5,730,608 and other U.S. and international patents	

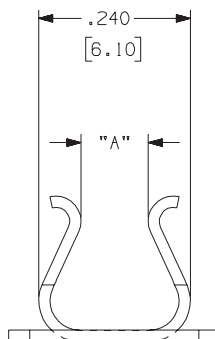
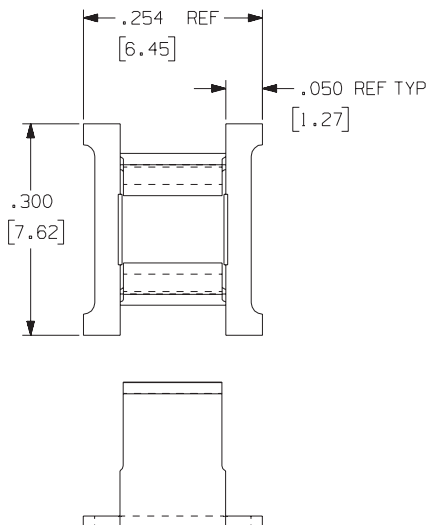

Recommended Solder Pad Geometry

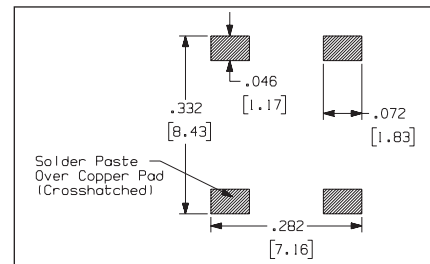

For drawings of our taped parts, please search for this part number on our website, www.zierick.com.

Part Numbers 1230, 1230T, 1230T-SR, 6230

Zierick recommends .006" stencil thickness for most applications. For other stencil thicknesses, call Zierick's product development department.

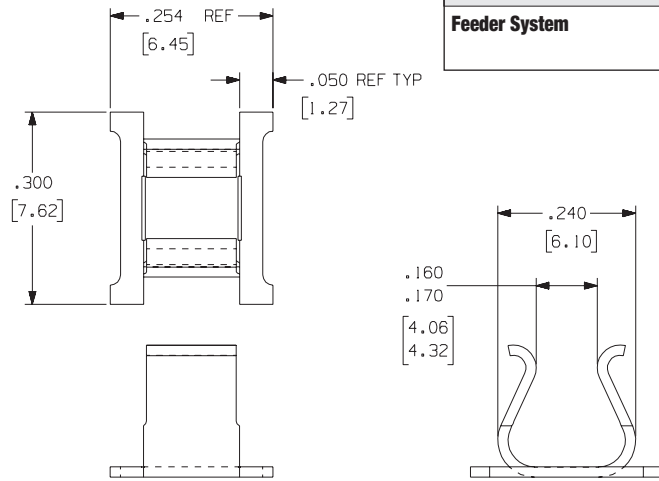

Loose Part No.	1230		
Reeled Part No.	6230		
Taped Part No.	1230T	1230T-SR	
Dim 'A'	0.165" (4.19mm)		
Material Thickness / Type	0.016" (0.41mm) Phosphor Bronze		
Standard Finish	100% Tin over Copper		
Current Rating	15 Amperes		
Feeder System	Surf-Shooter SMT™ Continuous Strip Feeder Standard 16mm Tape Feeder		

Recommended Solder Pad Geometry

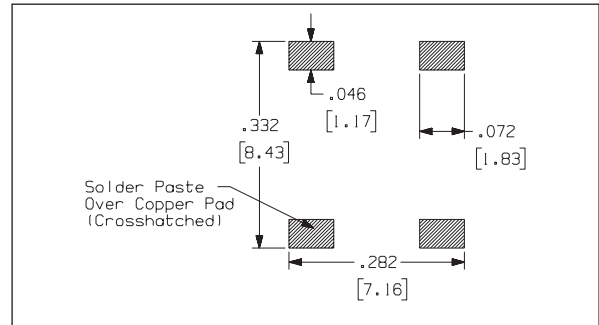

For drawings of our taped parts, please search for this part number on our website, www.zierick.com.

Auto Fuse Receptacles

Part Numbers 1237, 1237T, 1237T-SR, 1237-BMT, 1237-BMT-SR, 1237T-KT, 1237T-KT-SR, 1237-BMT-KT, 1237-BMT-KT-SR

Zierick recommends .006" stencil thickness for most applications. For other stencil thicknesses, call Zierick's product development department.

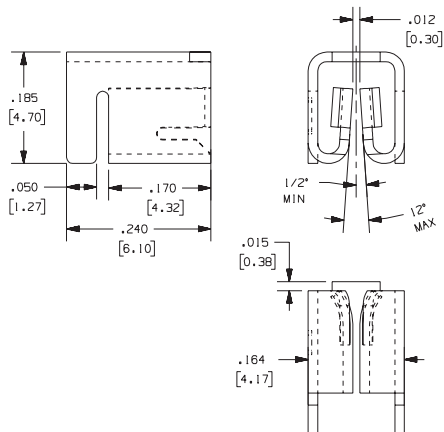

Loose Part No.	1237			
Reeled Part No.	6237			
Taped Part No.	1237T 1237T-SR	1237-BMT 1237-BMT-SR	1237T-KT 1237T-KT-SR	1237-BMT-KT 1237-BMT-KT-SR
Mating Terminal Size	0.025" (0.64mm) to 0.032" (0.81mm) thick			
Material Thickness / Type	0.016" (0.41mm) Brass			
Standard Finish	100% Tin over Copper			
Current Rating	25 Amperes			
Feeder System	Consult factory for Surf-Shooter SMT™ Continuous Strip Feeder P/N 6237 Standard 16mm Tape Feeder			
	U.S. Patent No. 5,730,608			

Optional use as Mini-Fuse Holder

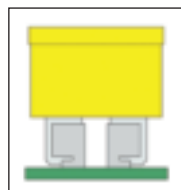

Optional use as ATC (Auto) Fuse Holder

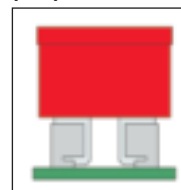

Recommended Solder Pad Geometry

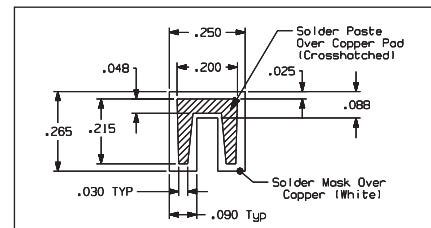

For drawings of our taped parts, please search for this part number on our website, www.zierick.com.

Features and Benefits

- Our Through-Board Sockets are designed to handle a high current, up to 7 Amps, depending on the application.
- They have a small footprint.
- They have a low profile.
- Their superior capacity accommodates either power or signal connection (with appropriate plating).
- The Sockets offer a high number of mating cycles.
- They are available in tape or bulk.
- They are ideal for demanding environments and high density applications.



**Part Numbers
1260, 1260T, 1260T-SR**

Zierick recommends .006" stencil thickness for most applications. For other stencil thicknesses, call Zierick's product development department.

Loose Part No.	1260
Taped Part Number	1260T
Small Reel Part No.	1260T-SR
Mating Pin Size	0.025" (0.64mm) Square or 0.025" (0.64mm) to 0.032" (0.81mm) Diameter Round Pins
Material Thickness / Type	0.005" (0.13mm) CDA 17200 Beryllium Copper
Standard Finish	Bright Tin over Copper
Current Rating	7 Amperes
Feeder System	Standard 16mm Tape Feeder for Taped Parts

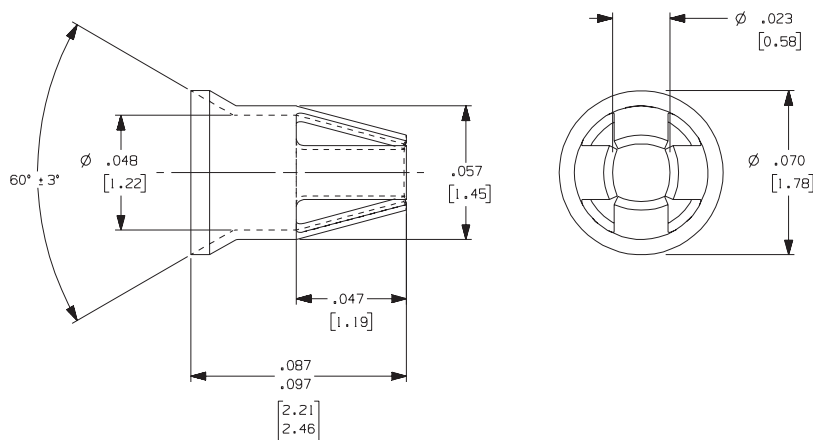

Recommended Solder Pad Geometry

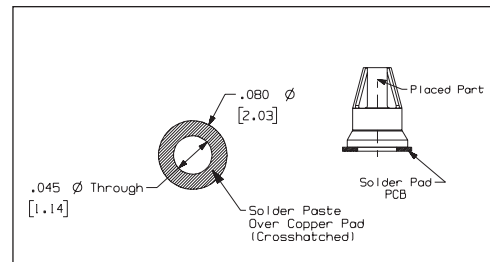

For drawings of our taped parts, please search for this part number on our website, www.zierick.com.

Features and Benefits

- High Current Rating, up to 7 Amps, depending on application
- Small footprint
- Low profile
- Can be either power or signal connection (with appropriate plating)
- High number of mating cycles
- Available in tape or bulk
- Ideal for demanding environments
- Square based socket for square mating pin applications



This square based socket is an upgraded version of our standard PN 1260, for square mating pin applications. PN 1260-SQ is consistently oriented in the tape pocket allowing the pick

and place machine to place it in the same angular position each time. This means that a square pin will reliably contact with the receptacle the same way each time

**Part Numbers
1260-SQ, 1260-SQ-T**

Zierick recommends .006" stencil thickness for most applications. For other stencil thicknesses, call Zierick's product development department.

Loose Part No.	1260-SQ
Taped Part Number	1260-SQ-T
Mating Pin Size	0.025" (0.64mm) Square or 0.025" (0.64mm) to 0.032" (0.81mm) Diameter Round Pins
Material Thickness / Type	0.005"(0.13mm) CDA 17200 Beryllium Copper
Standard Finish	Bright Tin over Copper
Current Rating	7 Amperes
Feeder System	Standard 16mm Tape Feeder for Taped Parts

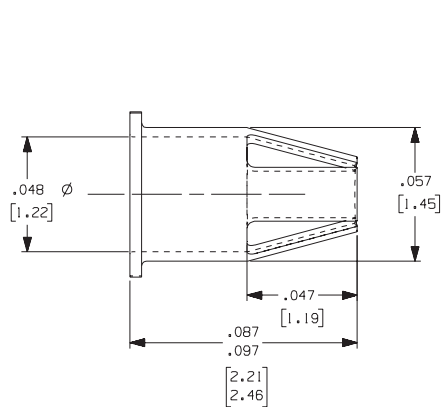

Recommended Solder Pad Geometry

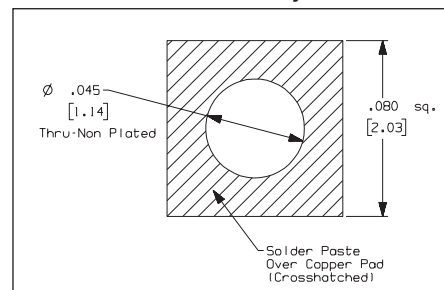

For drawings of our taped parts, please search for this part number on our website, www.zierick.com.

Part Numbers
1279, 1279T, 1279T-SR

Zierick recommends .006" stencil thickness for most applications. For other stencil thicknesses, call Zierick's product development department.

Loose Part No.	1279
Taped Part Number	1279T
Small Reel Part No.	1279T-SR
Mating Pin Size	0.062–0.066" (1.57–1.68mm) Diameter Round Pins
Material Thickness / Type	0.005"(0.13mm) CDA 17200 Beryllium Copper
Standard Finish	Bright Tin over Copper
Current Rating	7 Amperes
Feeder System	Standard 16mm Tape Feeder for Taped Parts

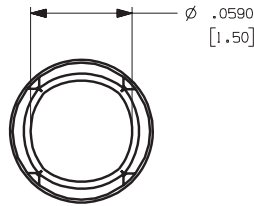
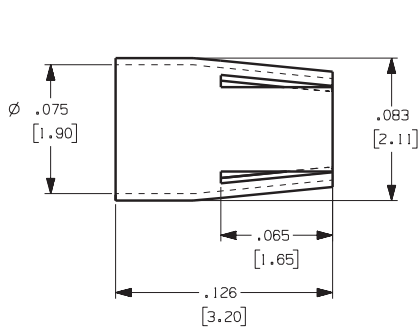

Recommended Solder Pad Geometry

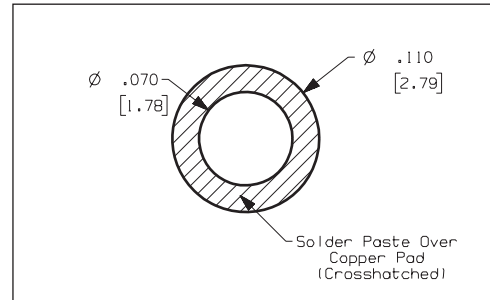

For drawings of our taped parts, please search for this part number on our website, www.zierick.com.

Part Numbers
1280, 1280T, 1280T-SR

Zierick recommends .006" stencil thickness for most applications. For other stencil thicknesses, call Zierick's product development department.

Loose Part No.	1280
Taped Part Number	1280T
Small Reel Part No.	1280T-SR
Mating Pin Size	0.038–0.044" (0.97–1.12mm) Diameter Round Pins
Material Thickness / Type	0.005"(0.13mm) CDA 17200 Beryllium Copper
Standard Finish	Bright Tin over Copper
Current Rating	7 Amperes
Feeder System	Standard 16mm Tape Feeder for Taped Parts

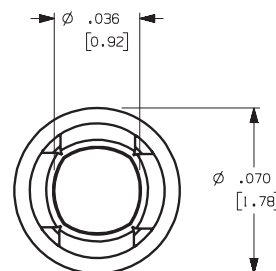
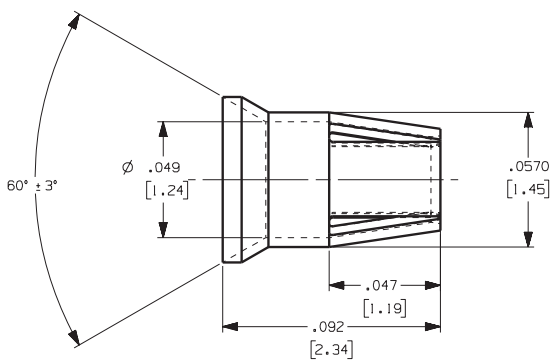

Recommended Solder Pad Geometry

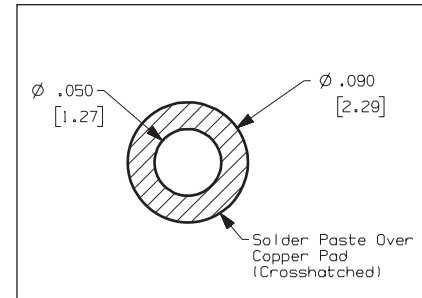

For drawings of our taped parts, please search for this part number on our website, www.zierick.com.